

---

**YDSR-5056A**

**SPECIFICATION**

			<b>CUSTOMER</b>
<b>NOTE:</b>			

**REVISION: 01**

**Outer Dimension:**

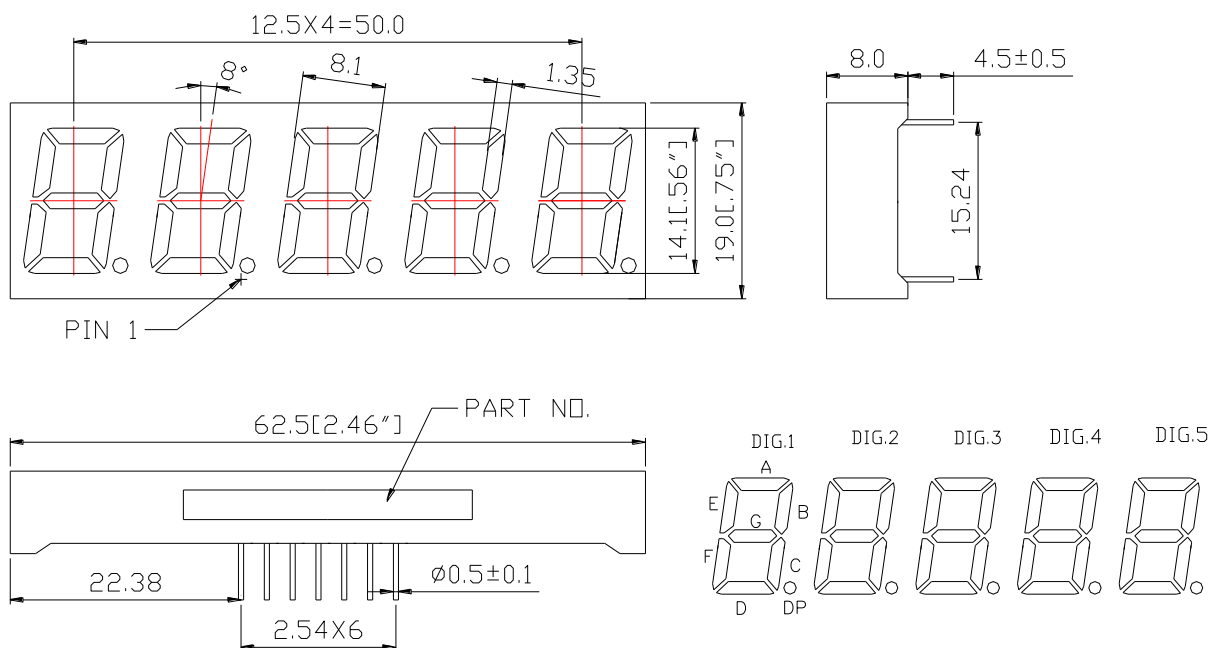

Notes: Unless otherwise stated, The tolerance is  $\pm 0.25$ mm.

**Circuit Diagram:**

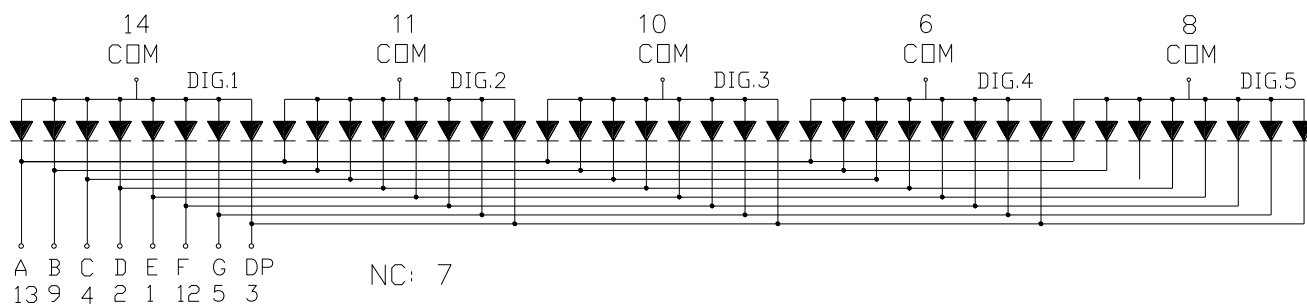

**Pin Connection:**

PIN NO.	CONNECTION	PIN NO.	CONNECTION
1	Cathode E	8	Common DIG. 5
2	Cathode D	9	Cathode B
3	Cathode DP	10	Common DIG.3
4	Cathode C	11	Common DIG.2
5	Cathode G	12	Cathode F
6	Common DIG.4	13	Cathode A
7	NC	14	Common DIG.1

■ **Features:**

- High Reliability
- Color : Red
- Low Power Requirement
- Easy Assembly

■ **Description:**

- Five Digit LED Display
- Digit Height:14.1mm(0.56" )
- Black Face and Encapsulation With Milky Epoxy

■ **Absolute Maximum Rating (Ta=25°C):**

Parameter	Symbol	Condition	Color	Rating	Units
Power Dissipation Segment	$P_d$	—	Red	50	mW
Forward Current Segment	$I_F$	—	Red	25	mA
Derating Of If Per Segment	$\Delta I_F$	$T_a \geq 25^\circ C$	Red	0.30	mA/°C
Peak Forward Current Per Segment	$I_{FP}$	1/10 Duty 10KHz	Red	100	mA
Reverse Voltage Per Segment	$V_R$	—	Red	5	V
Operating Temperature Range	$T_{opr}$	—	—	-35~+85	°C
Storage Temperature Range	$T_{stg}$	—	—	-35~+85	°C

■ **Electrical/Optical Characteristics Rating(Ta=25°C):**

Item	Symbol	Test conditions	Location	Color	Rating			Unit
					Min.	Typ.	Max	
Forward Voltage	$V_F$	$I_F=20mA$	Per Segment	Red	—	1.80	2.00	V
Reverse Current	$I_R$	$V_R=5V$	Per Segment	Red	—	—	100	$\mu A$
Luminous Intensity	$I_V$	$I_F=20mA$	Per Segment	Red	3201	6000	—	$\mu cd$
Wave Length	$\lambda_P$	$I_F=20mA$	Per Segment	Red	—	660	—	nm
	$\lambda_D$				—	643	—	
Spectral Line Half Width	$\Delta \lambda$	$I_F=20mA$	Per Segment	Red	—	20	—	nm
Luminous Intensity Matching Ratio (Segment To Segment)	$I_{v-m}$	$I_F=10mA$					2:1	

■ **Luminous Intensity Sorting:**

Rank	Symbol	Condition	Min	Max	Unit
J	J	$I_F=10mA$	3201	5050	$\mu cd$
K	K	$I_F=10mA$	5051	8000	$\mu cd$
L	L	$I_F=10mA$	8001	12650	$\mu cd$

■ **Soldering Conditions: Soldering Temp.  $\leq +260^\circ C$ , Soldering Time.  $\leq 3sec$ .**

(at 2mm Distance from The Case of Reflector Edge)