

# DATA SHEET for LED Lamp

(Chip LED)



<b>Part No.</b>	<b>WR106Y/W</b>	
Emitted Color	Chip Material	Lens Color
High Super Yellow	AlGaInP	Water Clear

## Contents

1. Features
2. Applications
3. Package Dimensions
4. Absolute Maximum Rating
5. Electron-Optical Characteristics
6. BIN Range
7. Typical Characteristic Curves
8. Package Label
9. Soldering Pad Dimensions
10. Soldering Conditions
11. Package Tape Specifications
12. Reliability
13. Cautions
14. Notes

Customer Confirm	Approved by	Checked by	Issued by

**Features :**

- Compatible with automatic placement equipment
- Compatible with reflow solder process
- Low power consumption and wide viewing angle
- This product doesn't contain restriction Substance, comply RoHS standard

**Applications :**

- Automotive and Telecommunication
- Flat backlight for LCD ,switch and symbol in telephone and fax
- General use for indicators

**Package Dimensions :**

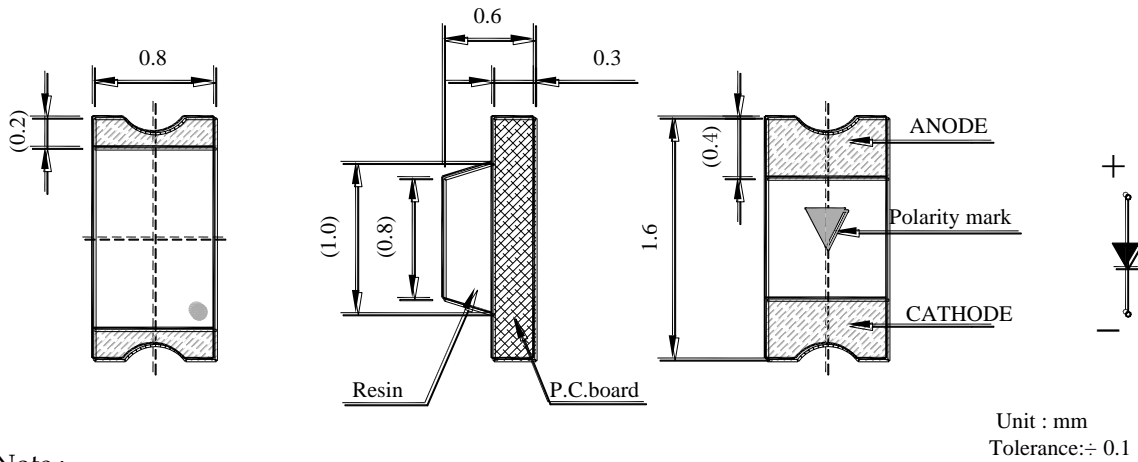

Note :

1. Electrodes: Au Plating
2. Encapsulating Resin: Epoxy Resin
3. Package: BT Resin

**Absolute Maximum Rating (Ta = 25°C)**

Parameter	Symbol	Maximum Rating	Unit
Power Dissipation	P <sub>d</sub>	60	mW
Pulse Forward Current (Duty 1/10 @ 1kHz)	I <sub>FP</sub>	80	mA
Continuous Forward Current	I <sub>F</sub>	20	mA
Reverse Voltage	V <sub>R</sub>	5	V
Operation Temperature	T <sub>opr</sub>	- 30 ~ 85	°C
Storage Temperature	T <sub>stg</sub>	- 40 ~ 100	°C
Soldering Temperature	T <sub>sol</sub>	260±5	°C

**Electron-Optical Characteristics (Ta = 25 °C)**

Parameter	Symbol	Min.	Typ.	Max.	Unit	Test Condition
Luminous Intensity	I <sub>v</sub>	45	100	120	mcd	I <sub>F</sub> =15 mA
Forward Voltage	V <sub>F</sub>	1.8		2.2	V	I <sub>F</sub> =15 mA
Reverse Current	I <sub>R</sub>			10	μA	V <sub>R</sub> =5V
Dominant Wavelength	λ <sub>d</sub>	584		590	nm	I <sub>F</sub> =15 mA
Spectral Line Half Width	Δλ		30		nm	I <sub>F</sub> =15 mA
Viewing Angle	2θ <sub>1/2</sub>		120		deg	I <sub>F</sub> =15 mA

Notes : 1.Tolerance of Luminous Intensity ±10%

2.Tolerance of Dominant Wavelength ±2nm

3. Tolerance of Forward voltage ±0.05V

4. Luminous Intensity is measured by WENRUN’s equipment on bare chips

**BIN Range**

1) Luminous Intensity (tolerance is ±10% @ I<sub>f</sub> =15 mA)

BIN Code	Min. (mcd)	Max. (mcd)
J	45	60
K	60	80
L	80	100
M	100	120
N	120	130

2) Dominant Wavelength (tolerance is ±2 nm @ I<sub>f</sub> =15 mA)

BIN Code	Min. (nm)	Max. (nm)
S	584	586
T	586	588
U	588	590

3) Forward Voltage (tolerance is ±0.05V @ I<sub>f</sub> =15 mA)

BIN Code	Min. (V)	Max. (V)
F	1.8	1.9
G	1.9	2.0
H	2.0	2.1
J	2.1	2.2

## Typical Characteristic Curves :

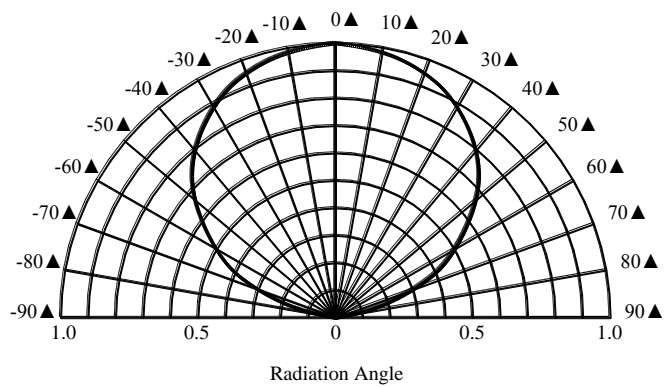
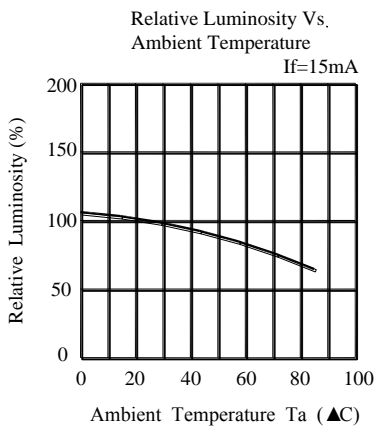
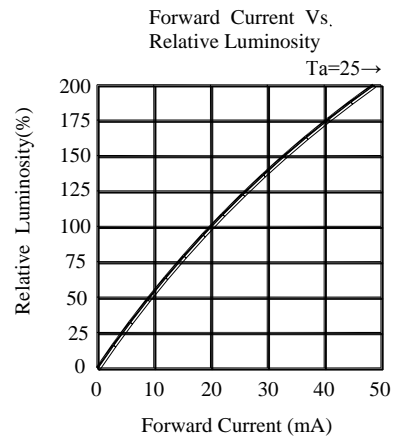
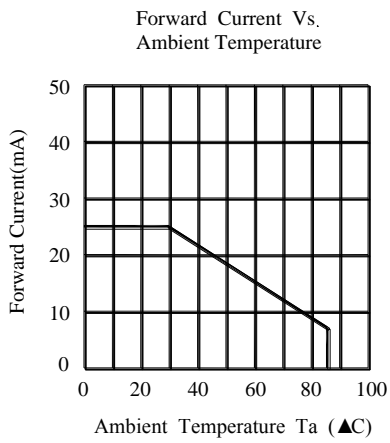
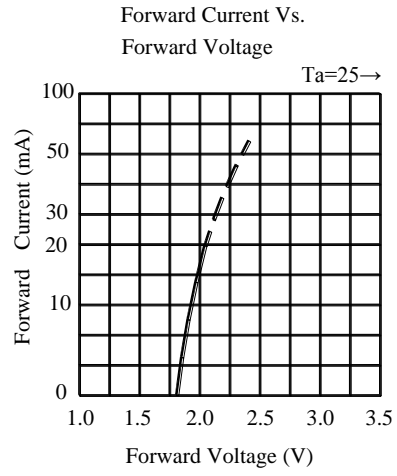
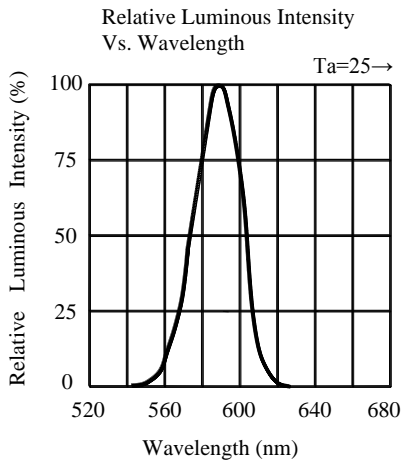

## Soldering Pad Dimensions

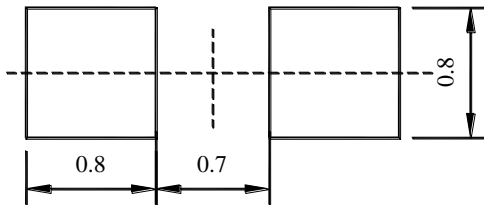

## Soldering Conditions (Maximum allowable soldering conditions)

Reflow soldering profile

<Pb-free solder>

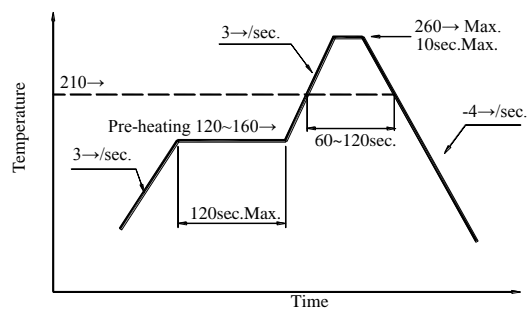

1. Reflow soldering should not be done more than two times.
2. Do not stress its resin while soldering.
3. After soldering, do not warp the circuit board.

**Package Tape Specification (1,000 ~ 4,000 pcs/Reel)**

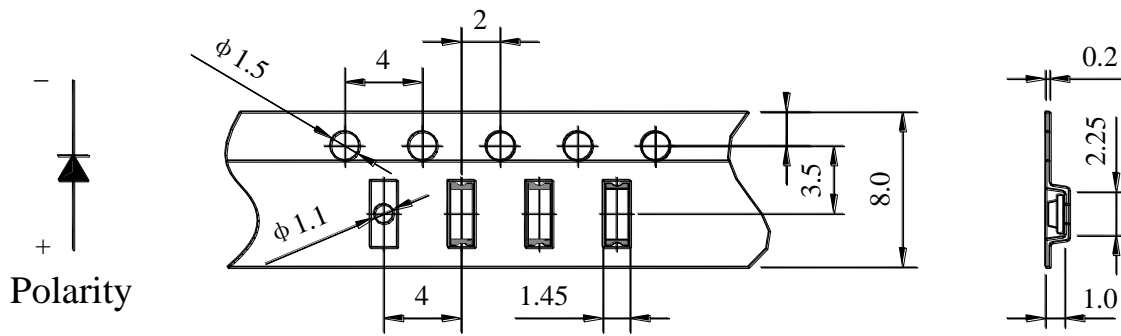
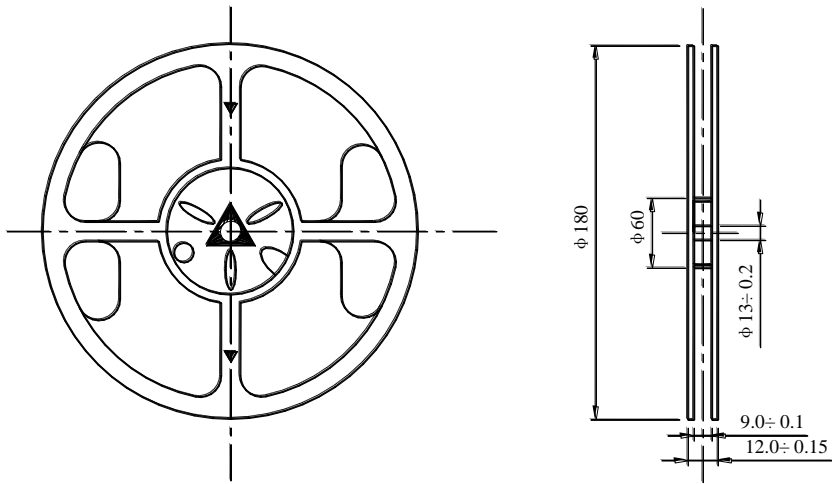

Reel Lead Min.60mm No LEDs

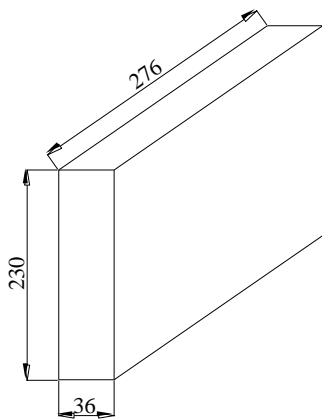

5 Reels in one Box

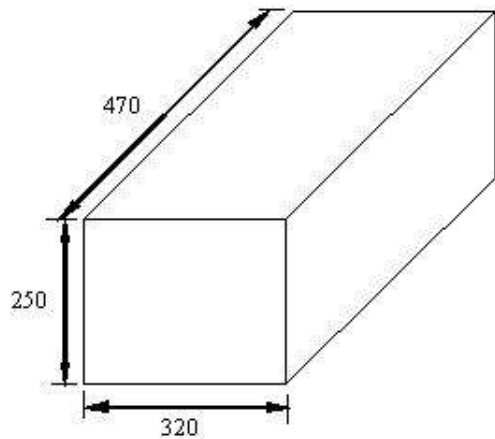

10 Boxes in one Carton

## Reliability

### 1) Test Items and Conditions

Test Item	Test Conditions	Sample	Ac/Re
Temperature Cycle	-40±5℃→25±5℃→100±5℃→25±5℃ (30min, 5min, 30min, 5min) 100 Cycles	20	0/1
High Temperature Storage	Ta : 100±5℃ Test time=1000HRS(-24HRS,+72HRS)	20	0/1
High Temperature And High Humidity Working	Ta : 85±5℃, RH:85±5%, IF=15mA Test time=500HRS(-24HRS,+72HRS)	20	0/1
Low Temperature Storage	Ta : -40±5℃ Test time=1000HRS(-24HRS,+72HRS)	20	0/1
Operating Life Test	Connect with a power IF=15mA Ta=Under room temperature Test time=1000HRS(-24HRS,+72HRS)	20	0/1
Thermal Shock	-40±5℃→100±5℃ (15min, 15min) 100 Cycles	20	0/1
IR-Reflow Pb-Free Process	①80℃②100℃③120℃④160℃⑤170℃⑥235℃ ⑦270℃⑧255℃, 60cm/min, 2 times	20	0/1

### 2) Criteria of judging the damage

Item	Symbol	Test condition	Criteria for judgement	
			Min.	Max.
Forward voltage	VF	IF=20 mA	/	U.S.L*1.1
Reverse current	IR	VR=5V	/	15uA
Luminous intensity	IV	IF=20 mA	L.S.L*0.7	/
Wave length	λD/λP	IF=20 mA	/	U.S.L±2nm
Appearance	/	View check	No mechanical damage	

\* U.S.L: Upper standard level

L.S.L: Lower standard level

## Cautions

1. Package : When moisture is absorbed into the package it may vaporize and expand during soldering. There is a possibility that this can cause exfoliation of the contacts and damage to the optical characteristics of the LEDs. So the moisture proof package is used to keep moisture to a minimum in the package.

2. Storage : Before opening the package: The LEDs should be kept at 5~30°C and 60%RH or less. The LEDs should be used within a year. After opening the package: The LED must be used within 24 hours, else should be kept at 5~30°C and 30% RH or less. The LEDs should be used within 7days after opening the package. If unused LEDs remain, they should be stored in moisture proof packages, recommended to return the LEDs to the original moisture proof bag and to reseal the moisture proof bag again. If the LEDs have exceeded the storage time, baking treatment should be performed more than 24 hours at  $60 \pm 5^\circ\text{C}$ .

3. Soldering Iron : Each terminal is to the tip of soldering iron temperature less than  $300^\circ\text{C}$  for 3 seconds within once in less than the soldering iron capacity 25 W. Leave two seconds and more internally, and do soldering of each terminal. Be careful because the damage of the product is often started at the time of the hand solder.

4. Repairing : Repairing should not be done after the LEDs have been soldered. When repairing is unavoidable, a double-head soldering iron should be used (as below figure). It should be confirmed beforehand whether the characteristics of the LEDs will or will not be damaged by repairing.

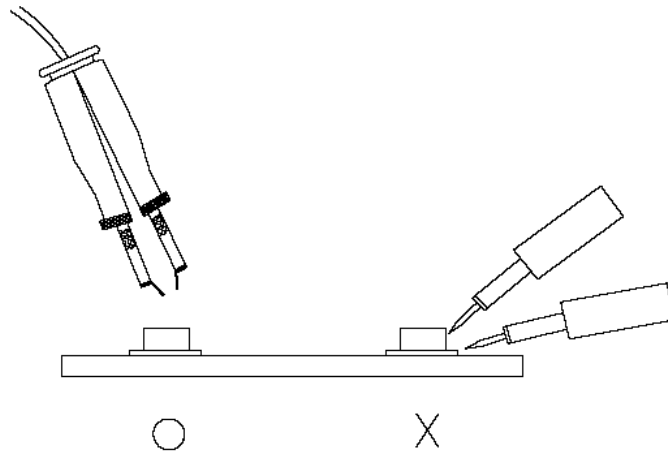

5. The LED electrode sections are comprised of a gold plated. The gold surface may be affected by environments which contain corrosive gases and so on. Please avoid conditions which may cause the LED to corrode or discolor. This corrosion or discoloration may cause difficulty during soldering operations. It is recommended that the User use the LEDs as soon as possible.

6. Please avoid rapid transitions in ambient temperature, especially in high humidity environments where condensation can occur.

**Notes :**

1. Above specification may be changed without notice. We will reserve authority on material change for above specification.

2. When using this product, please observe the absolute maximum ratings and the instructions for the specification sheets. We assume no responsibility for any damage resulting from use of the product which does not comply with the instructions included in the specification sheets.