

4611110008862

A

B

C

D

E

F

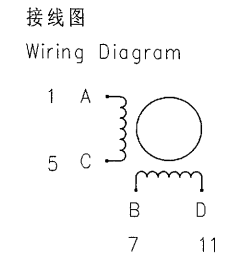
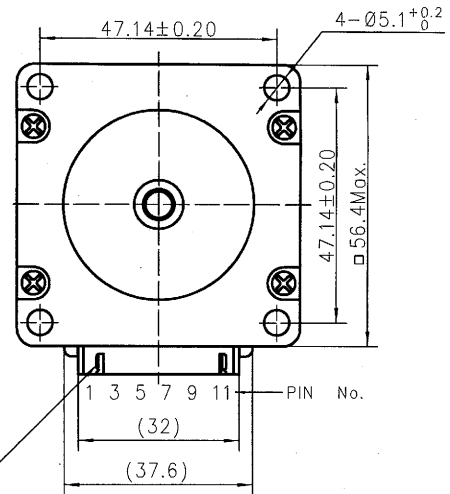
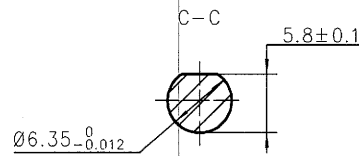
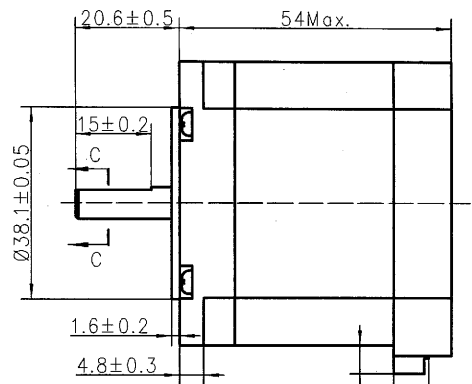
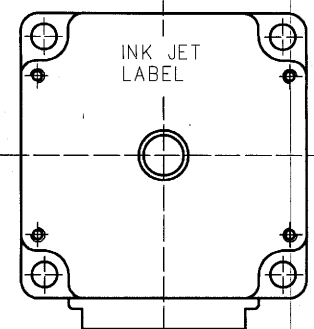

励磁顺序 vs. 旋转方向  
Exciting Sequence vs. Direction of Rotation

STEP	A	B	C	D	CCW
1	+	+	-	-	↑
2	-	+	+	-	
3	-	-	+	+	
4	+	-	-	+	

从安装面看为顺时针方向  
Clockwise view from mounting side

规格 Specifications

1. 相数 Number of Phase	2
2. 步距角 Step Angle	1.8°
3. 额定电压 Rated Voltage	4.2 V DC
4. 额定电流 Rated Current	2.1 Amp
5. 保持力矩 Holding Torque	1N.m Min.(Two phase on/rated current)
6. 相电阻 Phase Resistance	2 ohm±10%(20°C)
7. 相电感 Phase Inductance	7 mH±20%(1kHz 1V rms)
8. 转子惯量 Rotor Inertia	260g.cm <sup>2</sup>
9. 电机重量 Motor Weight	0.6kg
10. 绝缘等级 Insulation Class	B(130°C)

铭牌 Label Detail

MOONS' STEPPING MOTOR  
TYPE 23HS2068-04  
XXXXXXXX YY/MM/DD  
MADE IN CHINA

Work Order  
加工单号

Date Format  
日期格式

保 密

Unit: mm  
第一角画法  
FIRST ANGLE METHOD  
未注线性与角度尺寸公差  
Tolerances for linear and angular dimensions without individual tolerance indications  
GB/T 1804-m eqv ISO 2768-1:1:m  
未注形状与位置尺寸公差  
Geometrical tolerance for features without individual tolerance indications  
GB/T 1184-K eqv ISO 2768-2:1:K

批准 Approve	Jura	5.10
标准化 Standard	Jura	5.10
工艺 Technology	郑晓	11.05.10
审核 Check	张利辉	5.10
设计 Design	张利辉	2011.05.10

**MOONS'** Hybrid Stepping Motor  
Shanghai Moons' Electric Co., Ltd.  
This document is released for information only. Its reproduction in whole or in part or its dissemination to third parties is prohibited. All trademarks and registered trademarks appearing on this document are the property of their respective owners.

REV.	版本记录 REVISION RECORD	DATE	UNLESS OTHERWISE SPECIFIED	NAMES	SIGNATURE	DATE	Type: 23HS2068-04	Rev.A	SCALE 1:1	Sheet 1 of 1
1	原始版本 Original revision	2011.05.10								