

P	1	2	3	4	5	6	7	8	9	10	11	12	13	14	15	16	17	18	19	20
A±0.8	-	23.0	33.0	43.0	53.0	63.0	73.0	83.0	93.0	103.0	113.0	123.20	133.0	143.0	153.0	163.0	173.0	183.0	193.0	203.0
B±0.5	-	10.0	20.0	30.0	40.0	50.0	60.0	70.0	80.0	90.0	100.0	110.0	120.0	130.0	140.0	150.0	160.0	170.0	180.0	190.0

COMMERCIAL TOLERANCE	
0.5 to 3	± 0.12
over 3 to 6	± 0.16
over 6 to 10	± 0.18
over 10 to 30	± 0.22
over 30 to 50	± 0.25
over 50 to 80	± 0.35

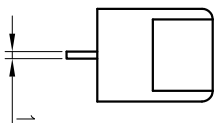
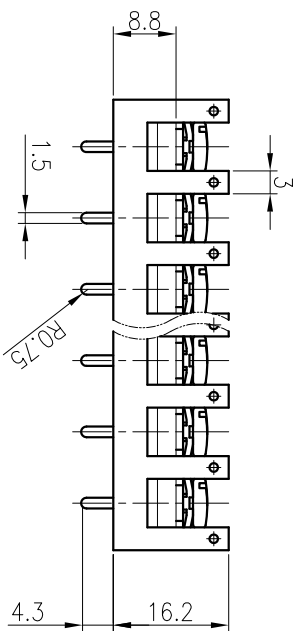
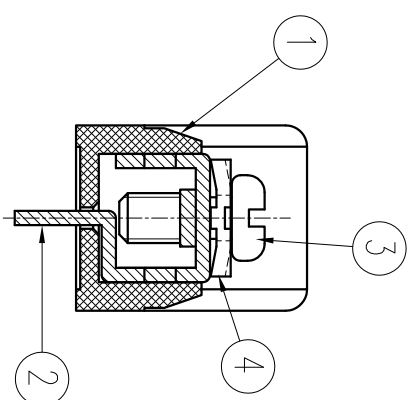
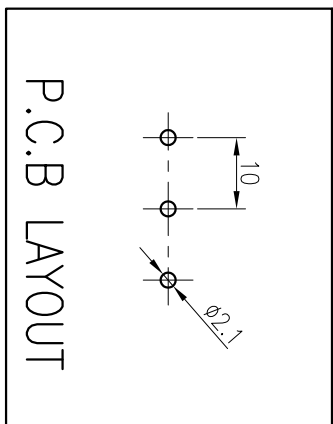
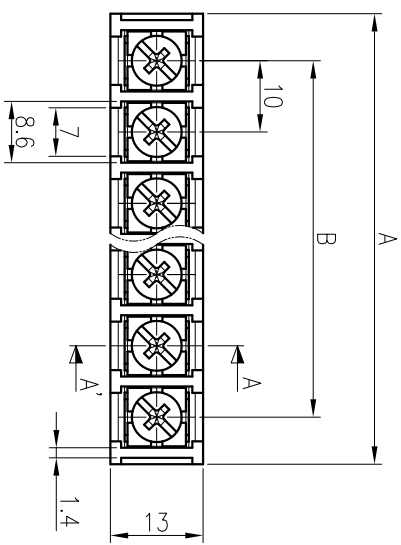

### SPECIFICATION

1. 정격 : 250V 20A
2. 절연 저항 : DC 500V 1000MΩ 이상
3. 내전압 : AC2000V/min
4. 사용온도범위 : -40°C ~ 85°C
5. 조임 Torque 권고치 : 5kgf·cm 이내

\*본 제품은 유해 물질 관리 기준치를 초과하지 않는 제품임 (RoHS Compliance)

DRAWN	CHECKED	CHECKED	APPROVED	THIRD ANGLE PROJECTION		
W.R.KIM				DATE.	UNIT	SCALE
09.05.06				2009.05.06	MM	1:1

TITLE		BR - 1002C
DWG No.	BRT - 137	

No.	PART No.	PART NAME	MATERIAL	Q'TY	REMARKS	FINISH
④	BOL-	WASHER	SPCC	P	φ8.2X8.2	Ni
③	BOL-	SCREW	SMCH10A	P	M3.5X8	Ni
②	DAM-950C	TERMINAL	BRASS	P	C2680R 1/2H t1.0	Sn
①	SAC-1002C	FRAME	PBT	1	UL94V-0 (G30)	BK



BEE-RYONG ELECTRONICS CO., LTD.