

MPL-01SE Series

Single Output, 1W Ultra-Miniature SIP AC/DC Power Supplies

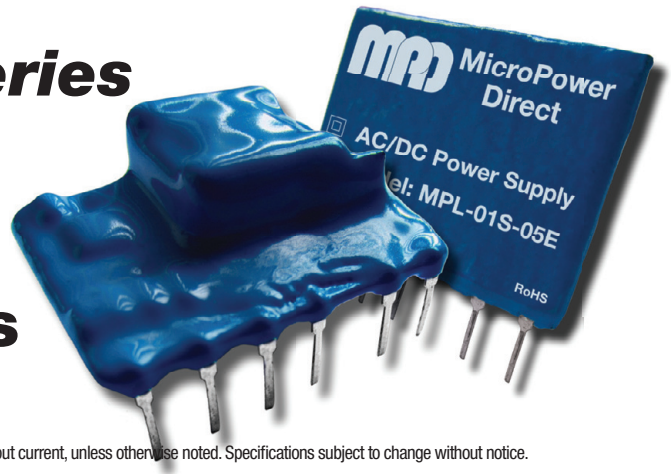

Key Features:

- 1W Output Power
- Universal 85-264 VAC Input
- EN 60950 Approved
- Meets IEC Safety Class II
- Right Angle Pins Available
- Single Regulated Output
- Meets EN 55022 Class A
- >300 kHour MTBF
- **Ultra-Miniature "SIP" Case**



MicroPower Direct

292 Page Street
Suite D
Stoughton, MA 02072
USA

T: (781) 344-8226

F: (781) 344-8481

E: sales@micropowerdirect.com

W: www.micropowerdirect.com



Electrical Specifications

Specifications typical @ +25°C, 230 VAC input voltage & rated output current, unless otherwise noted. Specifications subject to change without notice.

Input

Parameter	Conditions	Min.	Typ.	Max.	Units
Input Voltage Range		85		264	VAC
		70		400	VDC
Input Frequency		47		440	Hz
Input Current	See Model Selection Guide				
Inrush Current	115 VAC		10.0		A Pk
	230 VAC		20.0		

Output

Parameter	Conditions	Min.	Typ.	Max.	Units
Output Voltage Accuracy	See Model Selection Guide				
Standby Power Consumption				0.5	W
Line Regulation	V _{IN} = MIN to MAX		±1.5		%
Load Regulation	I _{OUT} = 5% to 100%		±2.5		%
Ripple & Noise (20 MHz)			50	120	mV P-P
Hold-Up Time	115 VAC	80			msec
	230 VAC	300			
Temperature Coefficient			±0.10		%/°C
Over Current Protection		110		140	%I _{OUT}
Short Circuit Protection	Continuous (Autorecovery)				

General

Parameter	Conditions	Min.	Typ.	Max.	Units
Isolation Voltage	Input to Output	3,000			VAC
Isolation Resistance	500 VDC	100			MΩ
Switching Frequency			50		kHz

EMI Characteristics

Parameter	Standard	Criteria	Level
Radiated Emissions, See Note 3	EN 55022		Class A
Conducted Emissions, See Note 3	EN 55022		Class A
ESD	EN 61000-4-2	B	±4 kV Contact
RS, See Note 4	EN 61000-4-3	A	10V/m
EFT, See Note 5	EN 61000-4-4	B	±2 kV
	EN 61000-4-4	B	±4 kV
Surge, See Note 6	EN 61000-4-5	B	±1 kV /±2 kV
CS, See Note 7	EN 61000-4-6	A	3 Vrms
PFM	EN 61000-4-8	A	10 A/m
Voltage Dips	EN 61000-4-11	B	0% - 70%

Environmental

Parameter	Conditions	Min.	Typ.	Max.	Units
Operating Temperature Range	Ambient	-40	+25	+85	°C
Operating Temperature Range	Surface (Case)			+90	°C
Storage Temperature Range		-40		+105	°C
Cooling	Free Air Convection (See Derating Curve)				
Humidity	RH, Non-condensing			85	%

Physical

Case Size	See Mechanical Drawings (Page 4)				
Case Material	Non-Conductive Epoxy (UL94-V0)				
Weight					0.28 Oz (8g)
Solder Temperature	Wave Soldering (5 - 10s)	255	260	265	°C
	Manual Soldering (3 - 5s)	350	360	370	

Reliability Specifications

Parameter	Conditions	Min.	Typ.	Max.	Units
MTBF	MIL HDBK 217F, 25°C, Gnd Benign	300			kHours
Safety Standards	EN 60950				
Safety Class	IEC 61140 Class II				

www.micropowerdirect.com

Model Number	Input		Output		Maximum Output Power (W)	Output Voltage Accuracy (%)	Capacitive Load (μ F, Max)	Efficiency (% Typ)	Fuse Rating Slow-Blow
	Current (A Max.)		Voltage (VDC)	Current (mA Max.)					
	115 VAC	230 VAC							
MPL-01S-05E(F)	0.120	0.040	5.0	200	1.0	\pm 10.0	220	66	1.0A/250 VAC
MPL-01S-09E(F)	0.120	0.040	9.0	111	1.0	\pm 5.0	100	67	1.0A/250 VAC
MPL-01S-12E(F)	0.120	0.040	12.0	83	1.0	\pm 5.0	100	70	1.0A/250 VAC
MPL-01S-15E(F)	0.120	0.040	15.0	67	1.0	\pm 5.0	100	69	1.0A/250 VAC
MPL-01S-24E(F)	0.120	0.040	24.0	42	1.0	\pm 5.0	100	68	1.0A/250 VAC

- Notes:**
- Operation at no load will not damage the units, however, they may not meet all specifications.
 - The External capacitors (C₁ & C₃) shown in the typical connection diagrams on page 3 are required to meet specified operation.
 - All units will meet EN 55022 (CE/RE) class A with the input circuit shown in the "Typical Connection 1" diagram on page 3. The **MPL01SE** will meet class B with the additional filtering shown in the "Typical Connection 2" diagram on page 3. **MPD** offers filter modules that will save on board space and make the input filter design easier. Contact the factory for more information.
 - To meet the requirements of EN 61000-4-3, (10V/m) external filtering (as shown in the "Typical Connection 2" diagram on page 3) is required. This filtering may be added discretely, or by using a filter module from **MPD**. Contact the factory for more information.
 - All units will meet EN 61000-4-4 (\pm 2 kV) with the input circuit shown in the "Typical Connection 1" diagram on page 3. To meet the requirements of EN 61000-4-4 (\pm 4 kV), external components (as shown in the "Typical Connection 2" diagram on page 3) are required. This filtering may be added discretely, or by using a filter module from **MPD**. Contact the factory for more information.
 - All units will meet the requirements of EN 61000-4-5 (\pm 1 kV/ \pm 2 kV), with the input circuit shown in the "Typical Connection 2" diagram on page 3. This filtering may be added discretely, or by using a filter module from **MPD**. Contact the factory for more information.
 - All units will meet the requirements of EN 61000-4-6 (3V rms), with the input circuit shown in the "Typical Connection 2" diagram on page 3. This filtering may be added discretely, or by using a filter module from **MPD**. Contact the factory for more information.
 - It is recommended that a fuse be used on the input of a power supply for protection. For the **MPL-01SE(F)** series, a 1.0A/250 VAC slow blow should be used.
 - The **MPL-01SE(F)** is available with the pins factory set to a 90° angle (see mechanical diagrams on page 4). To order units with this modification, add an "F" to the model number (i.e. **MPL-01S-12EF**).

Derating Curve, Output Power vs Temperature

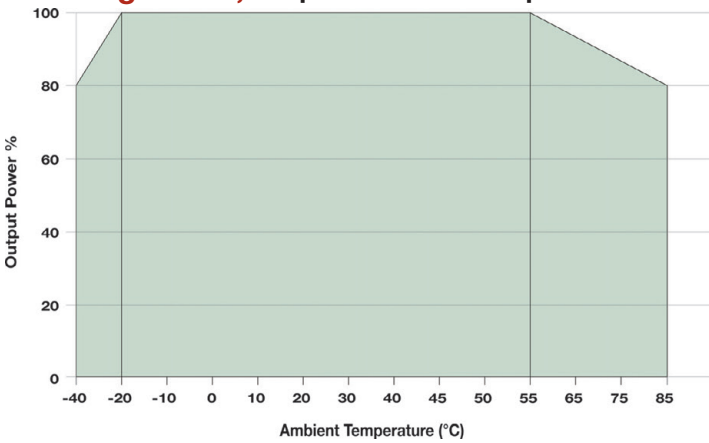

Derating Curve, Output Power vs Input Voltage

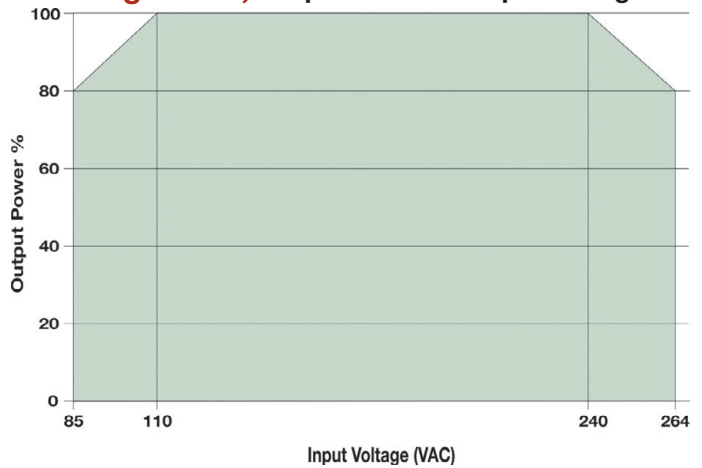

Efficiency vs Input Voltage VAC Input

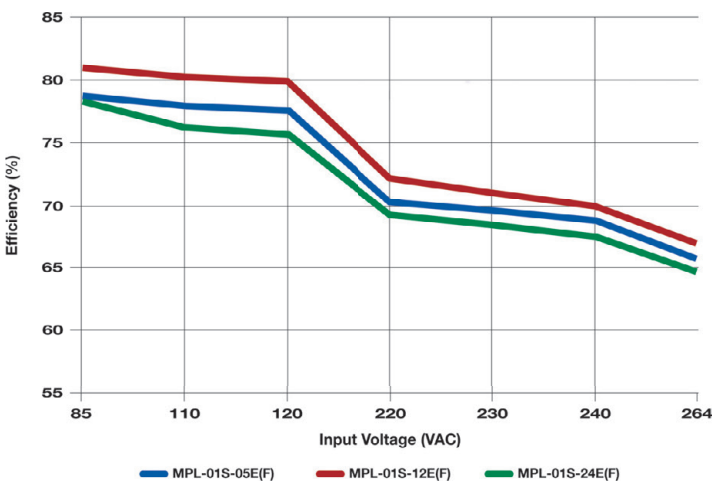

Efficiency vs Input Voltage VDC Input

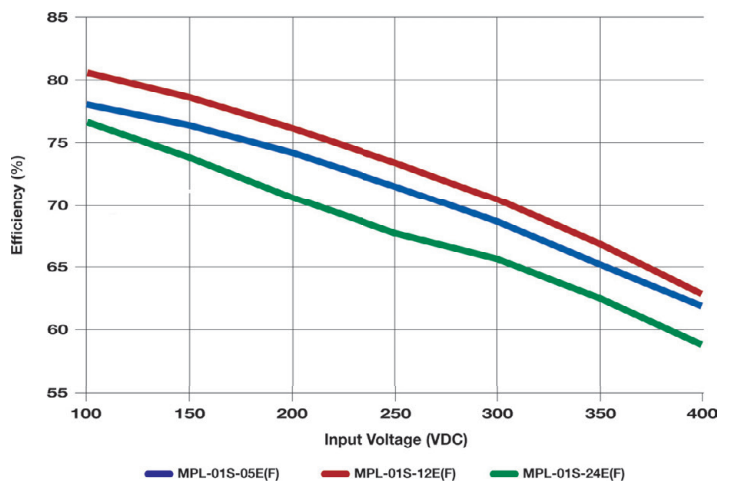

Typical Connection 1

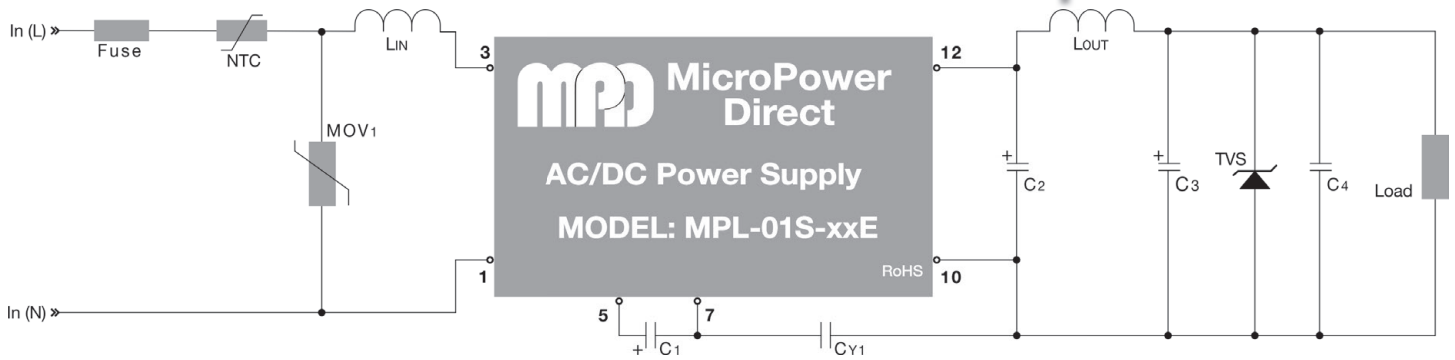

The diagram above illustrates a typical connection of the **MPL-01SE** series. With this connection, the unit will meet EN 55022 class A, EN 61000-4-2 ($\pm 4kV$), EN61000-4-4 ($\pm 2kV$), EN 61000-4-8 and EN 61000-4-11. Components C1 and C3 are required to meet specified operation limits. The recommended input components are a 5D-9 (NTC), S10k300 (MOV1) and 1 mH (LIN). The recommended output component values are given in the table below.

Typical Connection 2: With External EMC Components

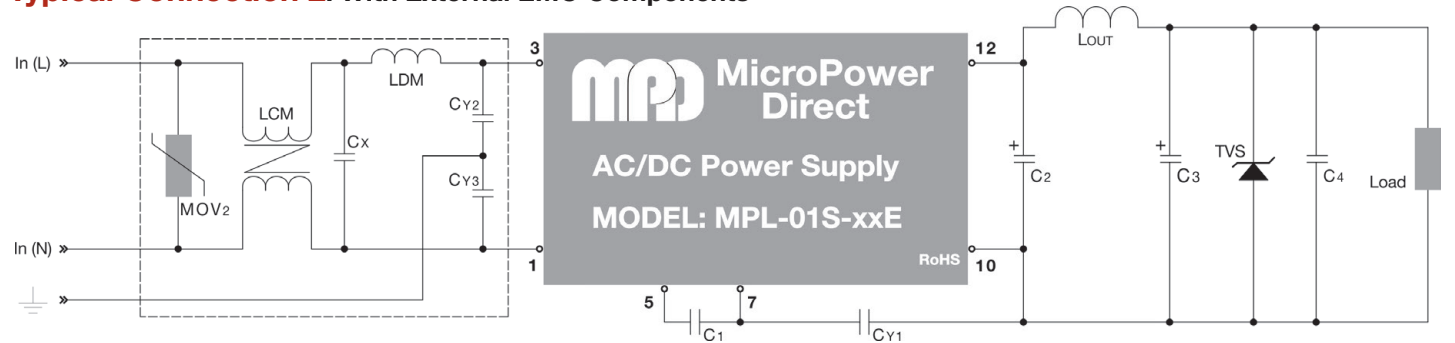

For applications that require meeting higher EMC standards, the circuit shown above is recommended. Some notes on this diagram (starting with the input circuit) are:

1. It is recommended that an external fuse be used. The recommended fuse is 1A/250V.
2. The capacitors Cx and Cyx are "safety" capacitors.
3. Capacitor C1 is a filter component. This capacitor is required to meet specified operation. It should be a high frequency, low ESR electrolytic capacitor. The recommended value is given in the table below.
4. Capacitors C2 and C3 are output filter components. Capacitor C3 is required to meet specified operation. Low ESR, high frequency electrolytic capacitors should be used. The recommended values are given in the table below.
5. Recommended values for components are:

6. The output TVS will help protect system circuitry if power supply fails. A recommended value is given in the table below.
7. Capacitor C4 is ceramic. This capacitor is used to filter high frequency noise. A recommended value is given in the table below.
8. All of the components within the dotted lines of the input EMC circuit are included in a filter module available from MPD. Please contact the factory for more information.

Model Number	External Components											
	MOV	LCM	Cx	LDM	CY2/CY3	C1 (Required)	CY1	C2	LOUT	C3 (Required)	C4	TVS
MPL-01S-05E	S10k300	3.5 mH	0.1 $\mu F/275$ VAC	5 mH	1 nF/400 VAC	10 $\mu F/400V$	1 nF/400 VAC	150 $\mu F/35V$	2.2 μH	68 $\mu F/35V$	0.1 $\mu F/50V$	SMBJ7.0A
MPL-01S-09E												SMBJ12A
MPL-01S-12E								SMBJ20A				
MPL-01S-15E								SMBJ30A				
MPL-01S-24E								SMBJ30A				

Typical Board Layout: With External EMC Components

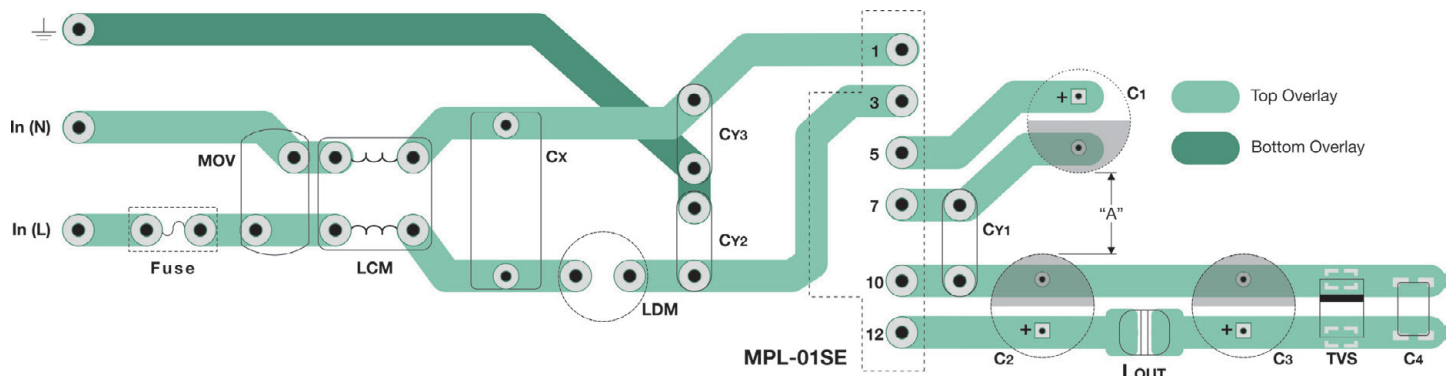

The diagram above shows a typical board layout for the **MPL-01SE** with the recommended EMI components shown in the "Typical Connection 2" diagram. Filter modules are available from MPD. Contact the factory for more information. To meet safety regulations, the board trace widths should be ≥ 3 mm, the distance between traces should be ≥ 6 mm, and the distance between traces and ground should be ≥ 6 mm. The distance "A" noted on the drawing should be ≥ 6.4 mm.

Mechanical Dimensions, Standard Models

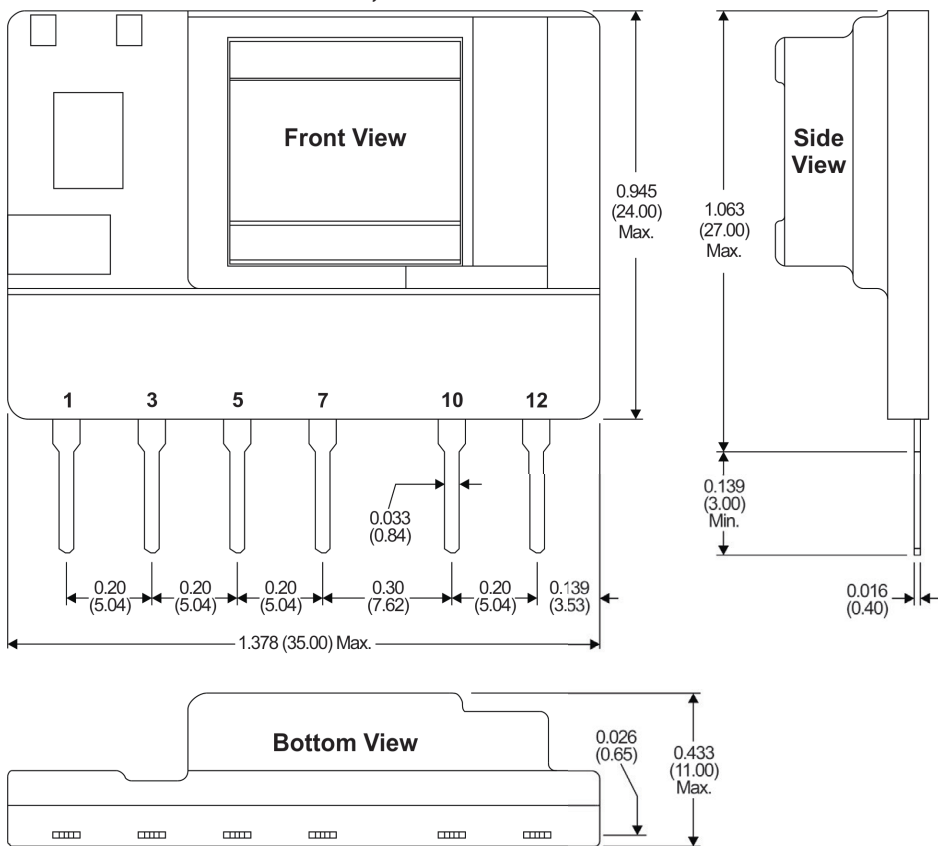

Mechanical Dimensions, Right Angle Pins

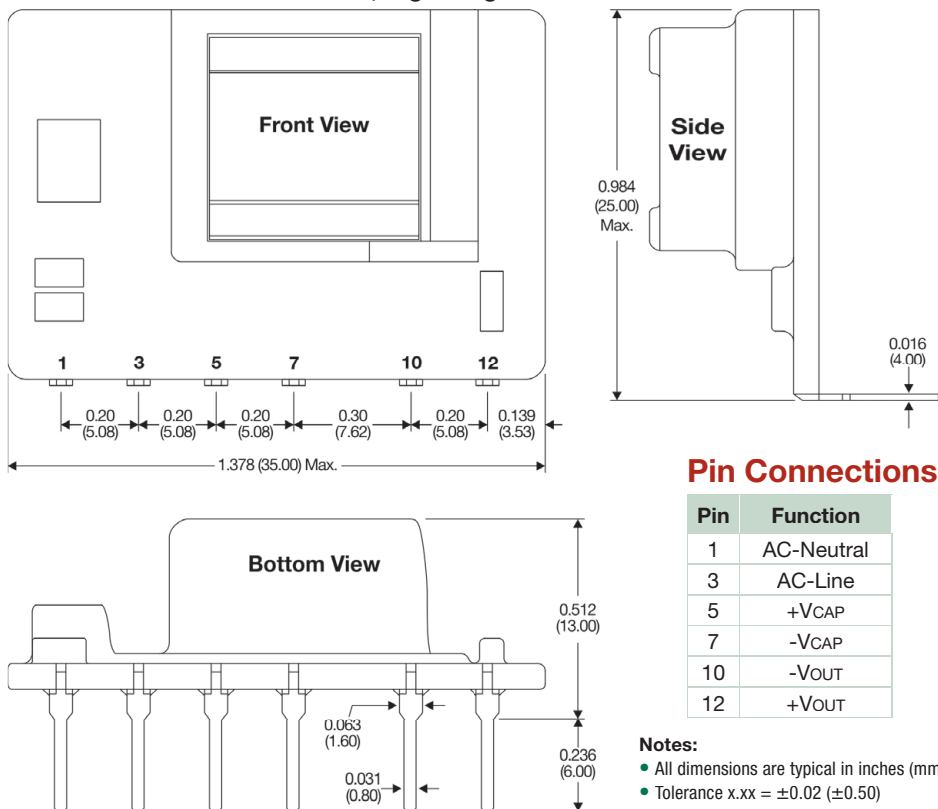

Pin Connections

Pin	Function
1	AC-Neutral
3	AC-Line
5	+VCAP
7	-VCAP
10	-VOUT
12	+VOUT

- Notes:**
- All dimensions are typical in inches (mm)
 - Tolerance x.xx = ±0.02 (±0.50)

MicroPower Direct offers a wide range of AC/DC power supplies in miniature SIP packages. Current models include:

MPL-03SE



Key Features:

- 3W Output Power
- Universal 85-264 VAC Input
- EN 60950 Approved
- Meets IEC Safety Class II
- Right Angle Pins Available
- Meets EN 55022 Class A
- >300 kHour MTBF
- **Ultra-Miniature "SIP" Case**

MPL-03SEUP

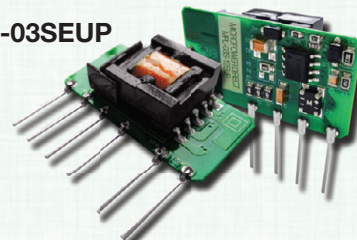

Key Features:

- 3W Output Power
- Universal 85-264 VAC Input
- EN 60950 Pending
- Meets IEC Safety Class II
- Standby Power Consumption <0.5W
- >200 kHour MTBF
- Also Available at 1W and 5W
- **Open, Ultra-Miniature "SIP" Package**

MPL-05SE



Key Features:

- 5W Output Power
- Universal 85-264 VAC Input
- EN 60950 Approved
- Meets IEC Safety Class II
- Right Angle Pins Available
- Meets EN 55022 Class A
- >300 kHour MTBF
- **Ultra-Miniature "SIP" Case**

Find full information on these power products & many others at the MPD website:

MICROPOWERDIRECT.COM



MicroPower Direct
We Power Your Success - For Less!