

ME02S Series

Low Cost, 0.25W Ultra-Miniature SIP DC/DC Converters



Key Features:

- 0.25W Output Power
- Ultra-Miniature SIP Case
- 48 Standard Models
- Up To 3,000 VDC Isolation
- >1.12 MHour MTBF
- Meets EN 55032 Class B
- -40°C to +85°C Operation



Also Available In
Ultra-Miniature
DIP Case

MicroPower Direct

292 Page Street
Suite D
Stoughton, MA 02072
USA

T: (781) 344-8226
F: (781) 344-8481
E: sales@micropowerdirect.com
W: www.micropowerdirect.com



Electrical Specifications

Specifications typical @ +25°C, nominal input voltage & rated output current, unless otherwise noted. Specifications subject to change without notice.

Input

Parameter	Conditions	Min.	Typ.	Max.	Units
Input Voltage Range	3.3 VDC Input	2.97	3.3	3.63	VDC
	5 VDC Input	4.50	5.0	5.50	
	12 VDC Input	10.80	12.0	13.20	
	15 VDC Input	13.50	15.0	16.50	
	24 VDC Input	21.60	24.0	26.40	
	48 VDC Input	43.20	48.0	52.80	
Input Reflected Ripple Current			20		mA P - P
Input Filter	Internal Capacitors				

Output

Parameter	Conditions	Min.	Typ.	Max.	Units
Output Voltage Accuracy			±3.0		%
Line Regulation	For VIN Change of 1%		±1.2		%
Load Regulation, See Note 1	See Model Selection Guide				
Ripple & Noise (20 MHz)			100		mV P - P
Temperature Coefficient			±0.02		%/°C
Output Short Circuit	Momentary (0.5 Sec.)				

General

Parameter	Conditions	Min.	Typ.	Max.	Units
Isolation Voltage	60 Seconds	1,000			VDC
	Units With "I" Suffix	3,000			
Isolation Resistance		1,000			MΩ
Isolation Capacitance			60		pF
Switching Frequency	See Note 2		80		kHz

Environmental

Parameter	Conditions	Min.	Typ.	Max.	Units
Operating Temperature Range	Ambient	-40		+85	°C
	Case			+100	
Storage Temperature Range		-40		+125	°C
Cooling	Free Air Convection				
Humidity	RH, Non-condensing			95	%

Physical

Case Size	See Mechanical Diagrams (Page 4)				
Case Material	Non-Conductive Black Plastic (UL-94V0)				
Weight	See Mechanical Diagrams (Page 4)				

Reliability Specifications

Parameter	Conditions	Min.	Typ.	Max.	Units
MTBF	MIL HDBK 217F, 25°C, Gnd Benign	1.121			MHours

Absolute Maximum Ratings

Parameter	Conditions	Min.	Typ.	Max.	Units
Input Voltage Surge (1 Sec)	3.3 VDC Input			5.0	VDC
	5 VDC Input			7.0	
	12 VDC Input			15.0	
	15 VDC Input			18.0	
	24 VDC Input			28.0	
	48 VDC Input			54.0	
Lead Temperature	1.5 mm From Case For 10 Sec			260	°C

Caution: Exceeding Absolute Maximum Ratings may damage the module. These are not continuous operating ratings.

www.micropowerdirect.com

Model Number	Input				Output		Load Regulation (% Typ)	Efficiency (% Typ)	Capacitive Load (µF, Max)	Fuse Rating Slow-Blow (mA)
	Voltage (VDC)		Current (mA)		Voltage (VDC)	Current (mA, Max)				
	Nominal	Range	Full-Load	No-Load						
ME0203S-03(I)	3.3	2.97 - 3.63	120	30	3.3	75.7	±20	63	100	250
ME0203S-05(I)	3.3	2.97 - 3.63	115	25	5.0	50.0	±10	66	100	250
ME0203S-07(I)	3.3	2.97 - 3.63	118	25	7.2	34.7	±10	64	100	250
ME0203S-09(I)	3.3	2.97 - 3.63	118	25	9.0	27.7	±10	64	100	250
ME0203S-12(I)	3.3	2.97 - 3.63	113	32	12.0	20.8	±10	67	100	250
ME0203S-15(I)	3.3	2.97 - 3.63	118	25	15.0	16.6	±10	64	100	250
ME0203S-18(I)	3.3	2.97 - 3.63	115	25	18.0	13.8	±10	66	100	250
ME0203S-24(I)	3.3	2.97 - 3.63	115	20	24.0	10.4	±10	66	100	250
ME0205S-03(I)	5.0	4.5 - 5.5	78	20	3.3	75.7	±20	64	100	150
ME0205S-05(I)	5.0	4.5 - 5.5	70	17	5.0	50.0	±10	71	100	150
ME0205S-07(I)	5.0	4.5 - 5.5	74	18	7.2	34.7	±10	68	100	150
ME0205S-09(I)	5.0	4.5 - 5.5	68	15	9.0	27.7	±10	73	100	150
ME0205S-12(I)	5.0	4.5 - 5.5	66	14	12.0	20.8	±10	76	100	150
ME0205S-15(I)	5.0	4.5 - 5.5	70	20	15.0	16.6	±10	71	100	150
ME0205S-18(I)	5.0	4.5 - 5.5	69	17	18.0	13.8	±10	72	100	150
ME0205S-24(I)	5.0	4.5 - 5.5	65	18	24.0	10.4	±10	77	100	150
ME0212S-03(I)	12	10.8 - 13.2	32	10	3.3	75.7	±20	65	100	75
ME0212S-05(I)	12	10.8 - 13.2	31	12	5.0	50.0	±10	67	100	75
ME0212S-07(I)	12	10.8 - 13.2	31	10	7.2	34.7	±10	67	100	75
ME0212S-09(I)	12	10.8 - 13.2	33	12	9.0	27.7	±10	64	100	75
ME0212S-12(I)	12	10.8 - 13.2	33	15	12.0	20.8	±10	63	100	75
ME0212S-15(I)	12	10.8 - 13.2	31	13	15.0	16.6	±10	67	100	75
ME0212S-18(I)	12	10.8 - 13.2	32	13	18.0	13.8	±10	65	100	75
ME0212S-24(I)	12	10.8 - 13.2	38	18	24.0	10.4	±10	55	100	75
ME0215S-03(I)	15	13.5 - 16.5	26	12	3.3	75.7	±20	63	100	50
ME0215S-05(I)	15	13.5 - 16.5	27	8	5.0	50.0	±10	62	100	50
ME0215S-07(I)	15	13.5 - 16.5	28	12	7.2	34.7	±10	60	100	50
ME0215S-09(I)	15	13.5 - 16.5	28	12	9.0	27.7	±10	60	100	50
ME0215S-12(I)	15	13.5 - 16.5	27	12	12.0	20.8	±10	62	100	50
ME0215S-15(I)	15	13.5 - 16.5	27	10	15.0	16.6	±10	61	100	50
ME0215S-18(I)	15	13.5 - 16.5	29	12	18.0	13.8	±10	57	100	50
ME0215S-24(I)	15	13.5 - 16.5	29	12	24.0	10.4	±10	57	100	50
ME0224S-03(I)	24	21.6 - 26.4	17	8	3.3	75.7	±20	60	100	40
ME0224S-05(I)	24	21.6 - 26.4	18	7	5.0	50.0	±10	58	100	40
ME0224S-07(I)	24	21.6 - 26.4	18	8	7.2	34.7	±10	57	100	40
ME0224S-09(I)	24	21.6 - 26.4	17	8	9.0	27.7	±10	62	100	40
ME0224S-12(I)	24	21.6 - 26.4	19	10	12.0	20.8	±10	56	100	40
ME0224S-15(I)	24	21.6 - 26.4	19	7	15.0	16.6	±10	55	100	40
ME0224S-18(I)	24	21.6 - 26.4	18	10	18.0	13.8	±10	57	100	40
ME0224S-24(I)	24	21.6 - 26.4	18	10	24.0	10.4	±10	59	100	40
ME0248S-03(I)	48	43.2 - 52.8	9	8	3.3	75.7	±20	55	100	20
ME0248S-05(I)	48	43.2 - 52.8	10	8	5.0	50.0	±10	53	100	20
ME0248S-07(I)	48	43.2 - 52.8	10	8	7.2	34.7	±10	54	100	20
ME0248S-09(I)	48	43.2 - 52.8	10	8	9.0	27.7	±10	54	100	20
ME0248S-12(I)	48	43.2 - 52.8	9	8	12.0	20.8	±10	55	100	20
ME0248S-15(I)	48	43.2 - 52.8	10	8	15.0	16.6	±10	54	100	20
ME0248S-18(I)	48	43.2 - 52.8	11	8	18.0	13.8	±10	49	100	20
ME0248S-24(I)	48	43.2 - 52.8	11	8	24.0	10.4	±10	49	100	20

For the 3 kV isolation models, add suffix "I" to model number (i.e. ME0224S-05I)

Notes:

1. Output load regulation is specified for a load change of 20% to 100%.
2. Switching frequency is typically 80 kHz, but may vary with differing operating conditions.
3. Operation at no-load will not damage these units. However, they may not meet all specifications.

4. These converters will operate without external components. However, to meet the specified EMI limits, a simple external input filter is required. See the input filter note on page 3 for more information.
5. All units are rated for operation at full output power to +85°C. Operation over +85°C without airflow is not

6. It is recommended that a fuse be used on the input of a power supply for protection. See the Model Selection table above for the correct rating.

Output Voltage vs Load: ME0205S-15

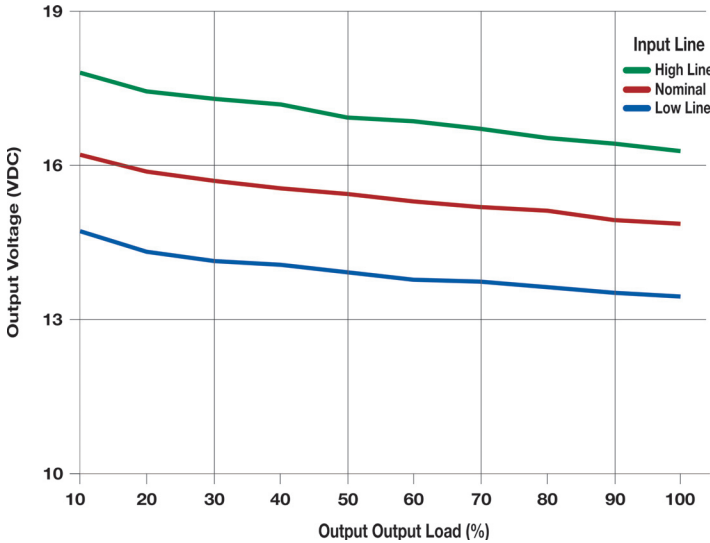

Output Voltage vs Load: ME0212S-15

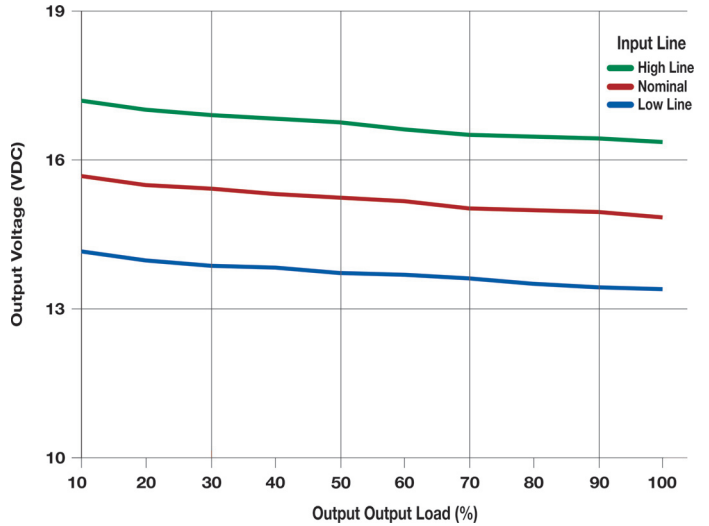

EMI/EMC Characteristics

Parameter	Standard	Criteria	Level
Radiated Emissions, See note 1	EN 55032		Class B
Conducted Emissions, See note 1	EN 55032		Class B
ESD	EN 61000-4-2	A	±6 kV Contact
			±8 kV Air
RS	EN 61000-4-3	A	10V/m
EFT, See Note 2	EN 61000-4-4	A	±2 kV
Surge, See Note 3	EN 61000-4-5	A	±0.5 kV
CS	EN 61000-4-6	A	10 Vrms
PFMF	EN 61000-4-8	A	1A/m

For many applications, the ME02S series will operate fine with minimum external components. However, if meeting the requirements of EMI/EMC standards (such as EN 55032) is required, a simple external filter circuit should be sufficient. This is illustrated in the typical connection diagram below.

Typical Connection

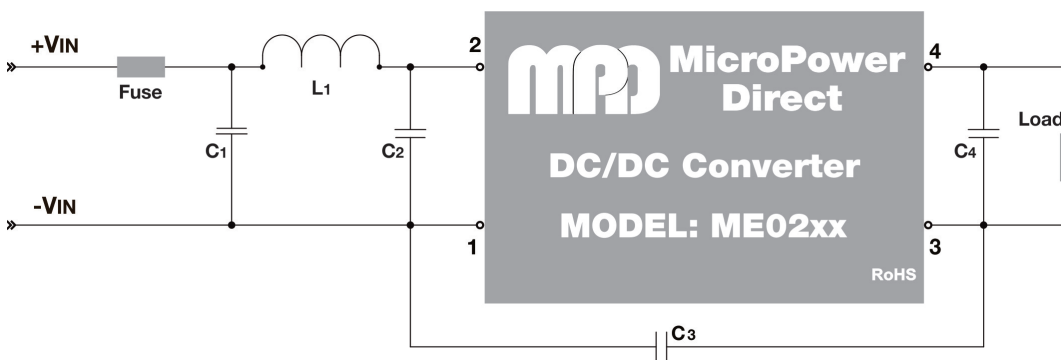

Notes:

- All input/output filtering capacitors should have a low equivalent impedance. Voltage derating of all capacitors should be 60% or greater. All components should be mounted as close to the converter as possible.
- To meet the requirements of EN 55032, the external components C1, L1, C2 and C3 are required. This is illustrated in the typical connection diagram at left. Values for these components are given in the table below. Contact the factory for more information.
- To meet the requirements of EN 61000-4-4, a larger external input capacitor is needed. In this case, the value of capacitor C1 should be changed to 470 µF/100V. Contact the factory for more information.
- To meet the requirements of EN 61000-4-5, a larger external input capacitor is needed. In this case, the value of capacitor C1 should be changed to 470 µF/100V. Contact the factory for more information.
- For noise sensitive applications, it is recommended that the external capacitor C4 be placed from the +VOUT pin to the -VOUT pin. Recommended values are given in the table. Care must be taken in choosing capacitors not to exceed the capacitive load specification for the unit.

The recommended component values are:

Input V	Fuse	C1	L1	C2	C3	C4
3.3 VIN	250 mA (Slow Blow)	1210, 2.2 µF/100V	18 µH	---	---	4.7 µF to 10 µF
5.0 VIN	150 mA (Slow Blow)	1210, 2.2 µF/100V	18 µH	---	---	4.7 µF to 10 µF
12 VIN	75 mA (Slow Blow)	1210, 2.2 µF/100V	18 µH	---	---	4.7 µF to 10 µF
15 VIN	50 mA (Slow Blow)	1210, 2.2 µF/100V	18 µH	---	---	4.7 µF to 10 µF
24 VIN	40 mA (Slow Blow)	1210, 2.2 µF/100V	18 µH	1210, 2.2 µF/100V	1206, 470 pF/2 kV	4.7 µF to 10 µF
48 VIN	20 mA (Slow Blow)	10 µF/100V	18 µH	1210, 2.2 µF/100V	1206, 470 pF/2 kV	4.7 µF to 10 µF

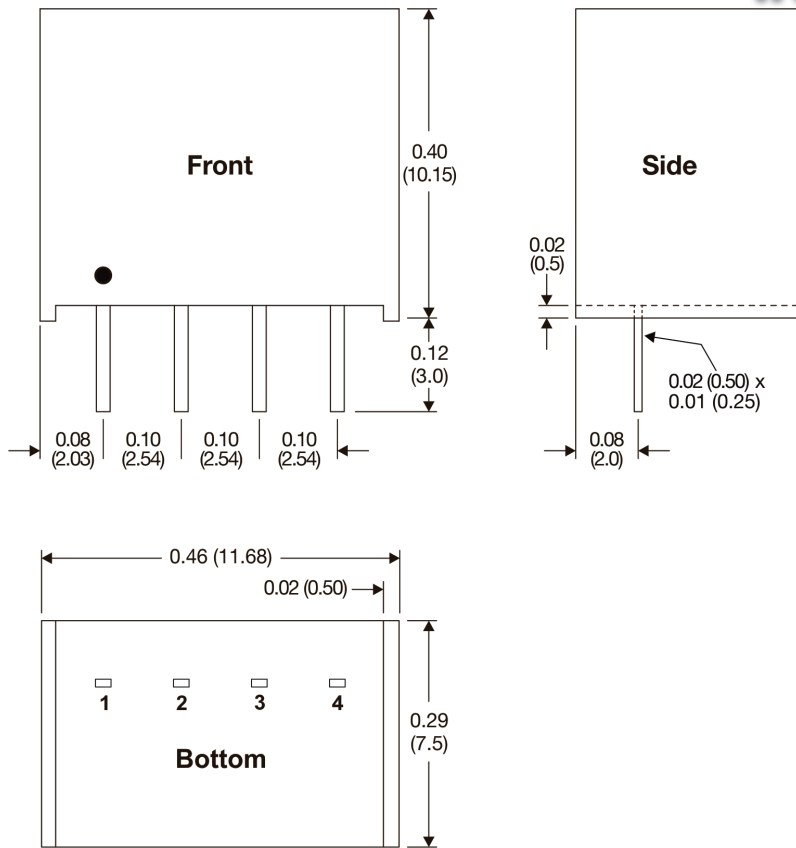

Pin Connections

Pin	Description
1	-VIN
2	+VIN
3	-VOUT
4	+VOUT

Notes:

- All dimensions are typical in inches (mm)
- Tolerance x.xx = ±0.02 (±0.50)
- Pin 1 is marked by a "dot" or indentation on the front of the unit
- Weight: 0.063 Oz (1.9g)

Mechanical Dimensions, All Other Models

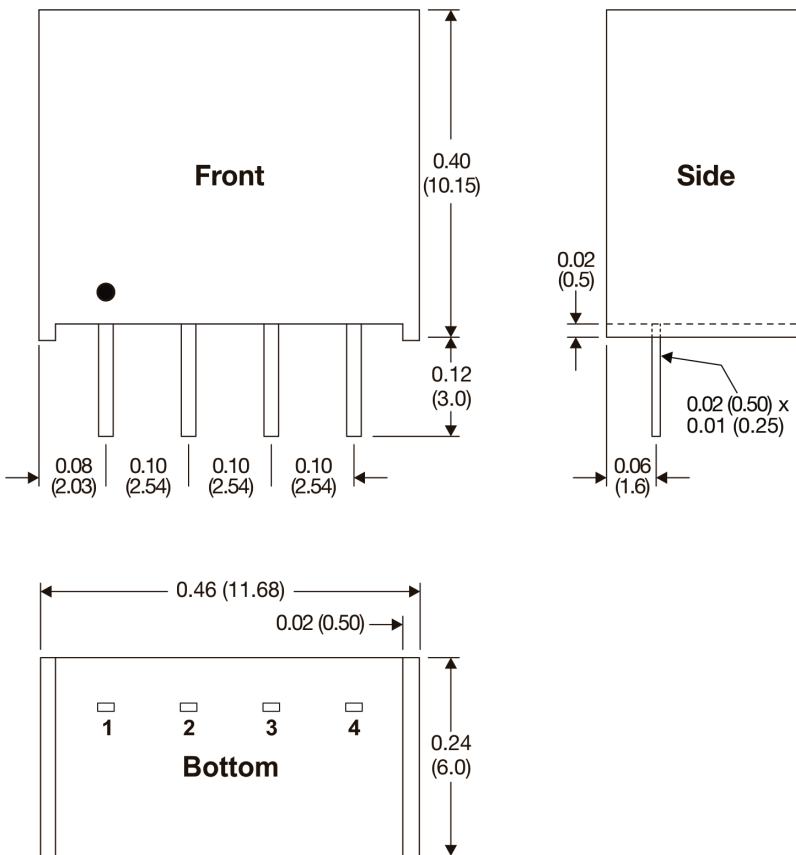

Pin Connections

Pin	Description
1	-VIN
2	+VIN
3	-VOUT
4	+VOUT

Notes:

- All dimensions are typical in inches (mm)
- Tolerance x.xx = ±0.02 (±0.50)
- Pin 1 is marked by a "dot" or indentation on the front of the unit
- Weight: 0.05 Oz (1.5g)