

Customer :

DATA SHEET for LED Lamp

(Standard LED Lamp)



Part No.	<i>LH30240</i>	
Emitted Color	Chip Material	Lens Color
Red	GaP	Red Diffused

Contents

1. Features
2. Descriptions
3. Applications
4. Package Dimensions
5. Absolute Maximum Rating
6. Electron-Optical Characteristics
7. Typical Characteristic Curves
8. Reliability
9. Label Form Specifications
10. Precautions in Use
11. Notes

Customer Confirm	Approved by	Checked by	Issued by

Features :

- High speed response
- High reliability and long life
- Low power consumption
- Available in red, blue, white, green, yellow colors
- Suitable for pulse operation
- This product doesn't contain restriction Substance, comply RoHS standard

Descriptions :

- The LED lamps are available with different colors, intensities, epoxy colors, etc.
- The series specially designed for applications requiring higher brightness.
- Superior performance in outdoor environment.

Applications :

- These lamp are widely used for various application.
- Indication of all kinds.
- Commercial use.

Package Dimensions :

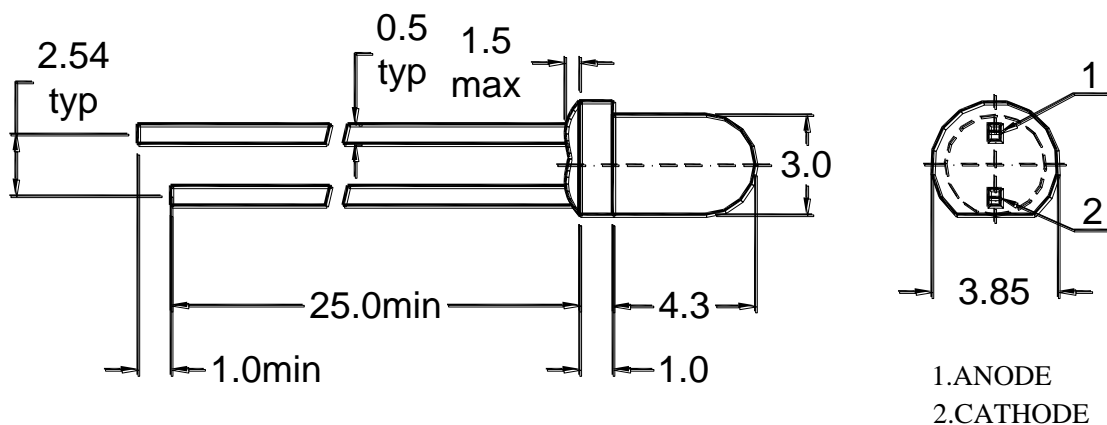

Note :

1. All dimensions are in millimeters(mm)
2. Tolerance is ± 0.25 mm unless otherwise noted
3. Protruded resin under flange is 1.5mm Max LED.

Absolute Maximum Rating (Ta = 25°C)

Parameter	Symbol	Maximum Rating	Unit
Power Dissipation	P _d	45	mW
Pulse Forward Current (Duty 1/10 @ 1kHz)	I _{FP}	50	mA
Continuous Forward Current	I _F	15	mA
Reverse Voltage	V _R	5	V
Operation Temperature	T _{opr}	-30 ~ 85	°C
Storage Temperature	T _{stg}	-40 ~ 100	°C
Soldering Temperature	T _{sol}	260±5	°C

Note : Soldering Time ≤5 seconds

Tsol condition : 3mm for the base of the epoxy bulb.

Electron-Optical Characteristics (Ta = 25°C)

Parameter	Symbol	Min.	Typ.	Max.	Unit	Test Condition
Luminous Intensity	I _v		2		mcd	I _F =20 mA
Forward Voltage	V _F		2.0	2.5	V	I _F =20 mA
Reverse Current	I _R			50	μA	V _R =5V
Dominant Wavelength	λ _d		655		nm	I _F =20 mA
Peak Emission Wavelength	λ _p		695		nm	I _F =20 mA
Spectral Line Half Width	Δλ		60		nm	I _F =20 mA
Viewing Angle	2θ1/2		40		deg	I _F =20 mA

Notes : 1. Tolerance of Luminous Intensity ±10%

2. Tolerance of Dominant Wavelength ±2nm

3. Tolerance of Forward voltage ±0.05V

Typical Characteristic Curves :

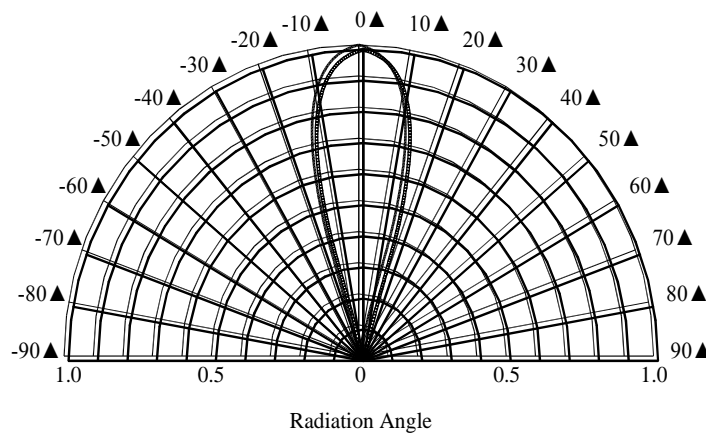
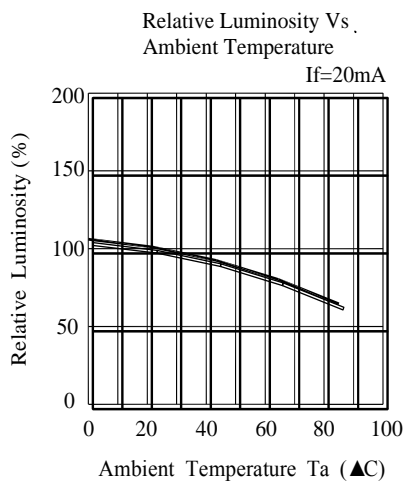
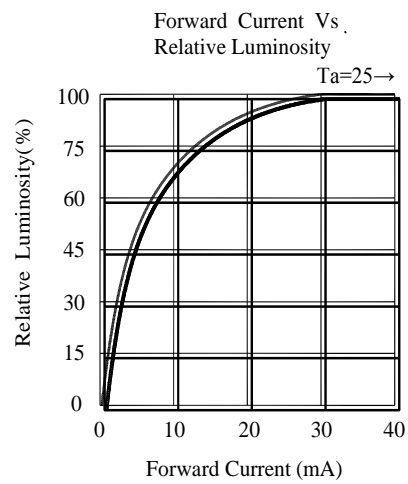
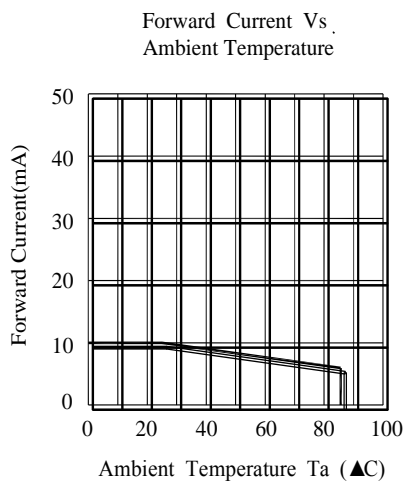
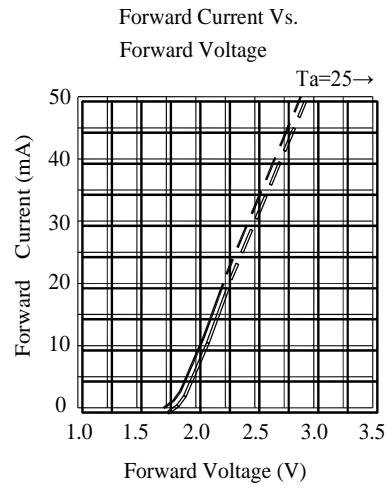
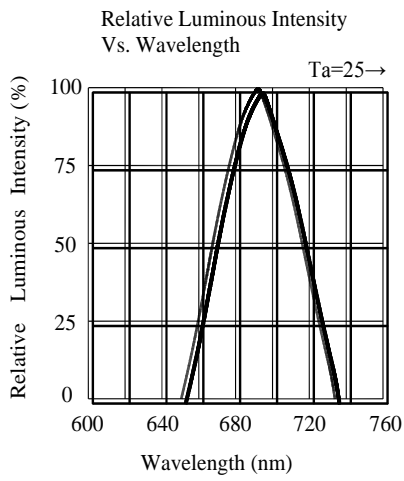

Reliability :

1) Test Items and Conditions

Test Item	Test Conditions	Duration	Sample	Ac/Re
Temperature Cycle	-40℃(30 min.) ~ 25℃(5 min.) ~ 100℃(30 min.) ~ 25℃(5 min.)	100 cycles	20	0/1
High Temp. Storage	Ta=100℃	1,000 hours	20	0/1
Temp. & Humidity Test	Ta=85℃, RH=85%	1,000 hours	20	0/1
Low Temp. Storage	Ta=-40℃	1,000 hours	20	0/1
Operating Life Test	Ta=25±5℃, DC IF=20mA	1,000 hours	20	0/1
Solder Heat	Tsol=260±5℃, 5sec	1 time	20	0/1
Thermal Shock	-40 ±5℃ → 100 ±5℃ 15 min. 15 min.	100 cycles	20	0/1

2) Criteria of judging the damage

Item	Symbol	Test condition	Criteria for judgement	
			Min.	Max.
Forward voltage	VF	IF=20 mA	/	U.S.L*1.1
Reverse current	IR	VR=5V	/	15uA
Luminous intensity	IV	IF=20 mA	L.S.L*0.7	/
Wave length	λD/λP	IF=20 mA	/	U.S.L±2nm
Appearance	/	View check	No mechanical damage	

* U.S.L: Upper standard level

L.S.L: Lower standard level

Label Form Specifications :

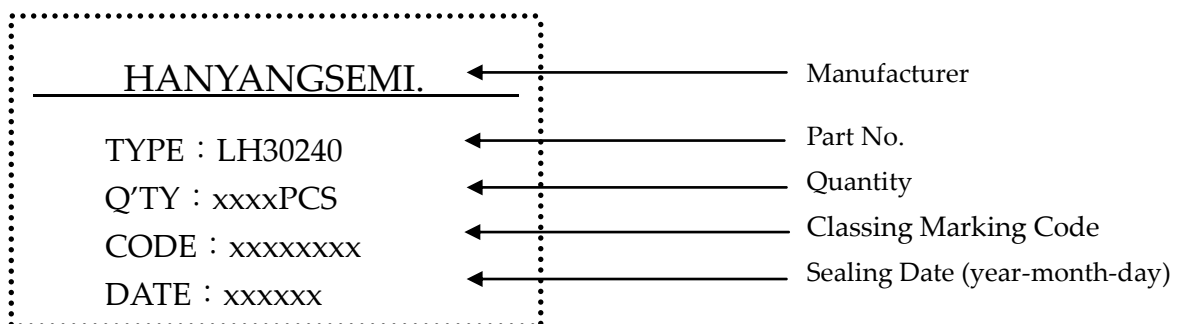

Precautions in Use :

A. Soldering Conditions

1. When soldering, leave the minimum clearance between the bottom of the resin and the soldering point.
2. Maximum allowable soldering conditions are.
 - Solder dipping : 260 °C max., 5 seconds max., one time.
 - Soldering iron : 350 °C max., 5 seconds max., one time.
3. Contact between molten solder and the resin must be avoided.
4. In soldering, do not put any stress on the lead frame, particularly when heated.

B. Lead frame Forming and Use

1. When forming leads, the leads should be bent at a point at least 3mm from the base of epoxy. Lead forming should be done before soldering.
2. Do not apply any bending stress to the base of the lead. The stress to the base may damage the LEDs characteristics.
3. When mounting the LEDs onto a printed circuit board, the holes on the circuit board should be exactly aligned with the leads of the LEDs.
4. Please avoid conditions which may cause the LED to corrode, tarnish or discolor. This corrosion or discoloration may cause difficulty during soldering operations. It is recommended that the LEDs be used as soon as possible.
5. Please avoid rapid transitions in ambient temperature, especially, in high humidity environments.

C. Storage

1. The LEDs should be stored at 30 °C or less and 70%RH or less after being shipped from Wenrun and the storage life limits are 3 months. If the LEDs are stored for 3 months or more, they can be stored for a year in a sealed container with a nitrogen atmosphere and moisture absorbent material.
2. Please avoid rapid transitions in ambient temperature, especially, in high humidity environments where condensation can occur.

D. Cleaning

1. When necessary, cleaning should occur only with isopropyl alcohol at room temperature for a duration of no more than one minute. Dry at room temperature before use.
2. Do not clean the LEDs by the ultrasonic. When it is absolutely necessary, the influence of ultrasonic cleaning on the LEDs depends on factors such as ultrasonic power and the assembled condition. Ultrasonic cleaning shall be pre-qualified to ensure this will not cause damage to the LED.

E. Circuit Protection

1. Below the zener reference voltage V_z , all the current flows through LED and as the voltage rises to V_z , the zener diode breakdown. If the voltage tries to rise above V_z current flows through the zener branch to keep the voltage at exactly V_z .
2. When the LED is connected using serial circuit, if either piece of LED is no light up but current can not flow through causing others to light down.. In new design, the LEDs parallel with zener diode, if either piece of LED is no light up but current can flow through causing others to light up

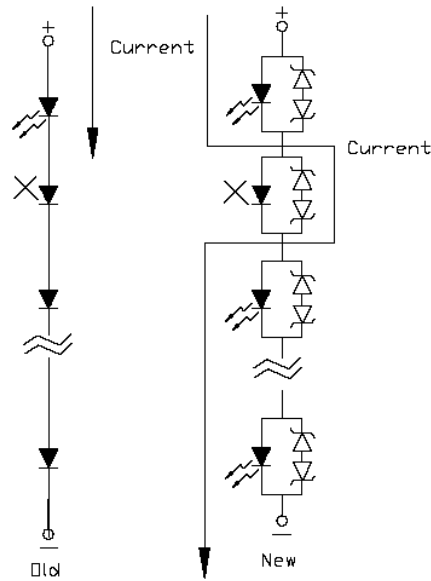

F. Heat Management

1. Heat management of LEDs must be taken into consideration during the design stage of LED application. The current should be de-rated appropriately by referring to the de-rating curve found in each product specification .
2. The temperature surrounding the LED in the application should be controlled. Please refer to the data sheet de-rating curve.

Note :

1. Above specification may be changed without notice. We will reserve authority on material change for above specification.
2. When using this product, please observe the absolute maximum ratings and the instructions for the specification sheets. We assume no responsibility for any damage resulting from use of the product which does not comply with the instructions included in the specification sheets.