

RoHS Compliant

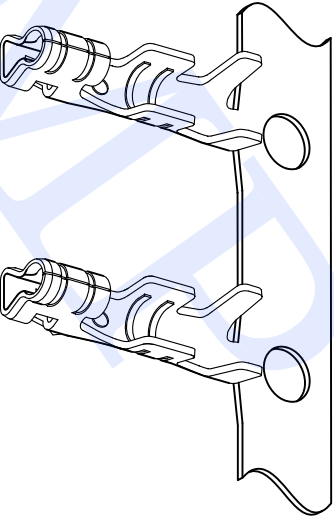
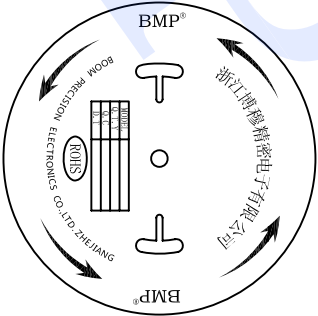
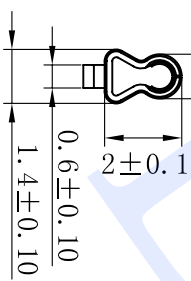
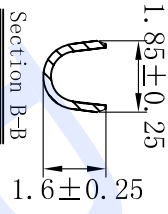
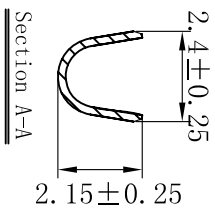
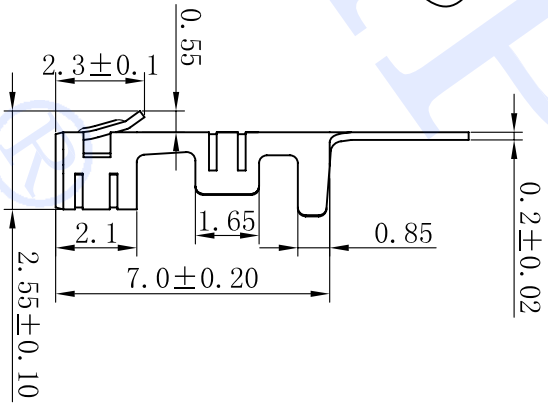
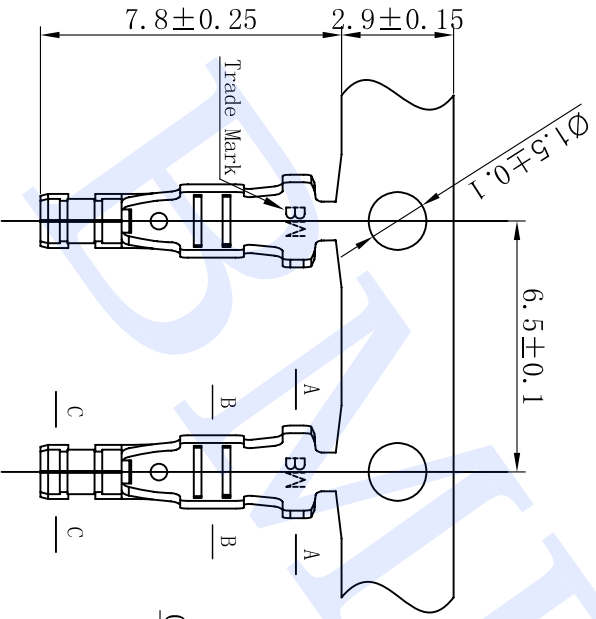

NOTE:
 Material: phosphor bronze C5191R-H
 Coating: Ni 30-50 μ " +Tin 100-150 μ "
 Wire Range: AWG 22 # -28 #
 Insulation O. D.: φ1.9mm (max)
 Plating Process: plating after stamp or stamp after plating
 Insertion force: 2.5-4.5N Pullout force ≥1.5N Retentivity ≥15N
 qty/reel: 10000 pcs

BMP 浙江博穆精密电子有限公司
 BOOM PRECISION ELECTRONICS CO., LTD. ZHEJIANG
 ADD: 浙江省乐清市虹桥镇西工业区黎明西路187号
 TEL: 0086-577-62316699 FAX: 0086-577-62312407
 Http://www.boomele.com E-mail: boomele@boomele.com

PART NO.	5264-PT		Part No.	Material	Color/Finish	Remark	APPROVAL
	2.50mm Wire to Board						
TITLE	2.50mm Wire to Board	SCALE	1:1	TOLERANCE	DATE	ODD NUMBERS	REV
THIRD ANGLE	UNIT	SHEET NO	mm	.X±0.20 .XXX±0.05	2013.08.30		A
				.XX±0.10 ANGLE±2°			APPROVED:
							Z.X