

DATASHEET & RELIABILITY DATA

SD1R5 SERIES

(주)오디피

Open Digital Power Corp.

Contents

- Introduction	-----	3~4 page
- Datasheet	-----	5~9 page
1. Internal Circuit Architecture		
2. Maximum Ratings		
3. Electrical Characteristics		
4. Isolation Characteristics		
5. General Characteristics		
6. Environment		
7. Characteristics Curves		
- Reliability Data	-----	10~15 page
1. MTBF		
2. Environmental Stress Test		
3. Main Components Δt Test		
4. Derating of semiconductor (FET, Rectifier diode)		
5. Abnormal Test		
- Application Sheet	-----	16~23 page
1. Basic Connection		
2. Input Section		
3. Output Section		
4. Operating Method		
5. Environment		
6. Isolation		
7. Outline Dimensions		

MAX. Power 1.5W Isolated DC-DC Converter

SDS1R5 Series Small Compact Size DC-DC Converter

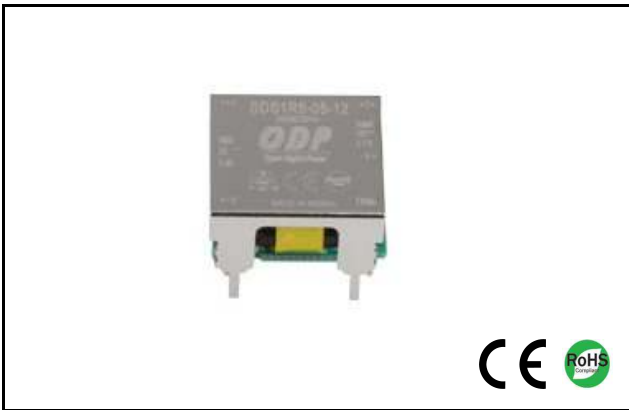

Features

- Small Compact Size
- High Efficiency
- Isolated Input - Output
- Wide operating temperature range (-40°C to 85°C)
- Long Life Design (Employ only Ceramic Capacitor)
- Built-in over current protection circuit
- Wide 2 : 1 input range
- Adjustable output voltage (single output)
- Safety standard : CE approved
- RoHS compatible design

Applications

- Data and telecommunication
- FA control
- Datacommunication electronic equipments

Environment

- Operating Temperature : -40°C ~ 85°C
- Operating Humidity : 5% ~ 95% RH (Non condensing)
- Storage Temperature : -40°C ~ 105°C
- Cooling : Free-Air Convection
- MTBF : 9.0 x 10⁵ hrs

Model Name Structure

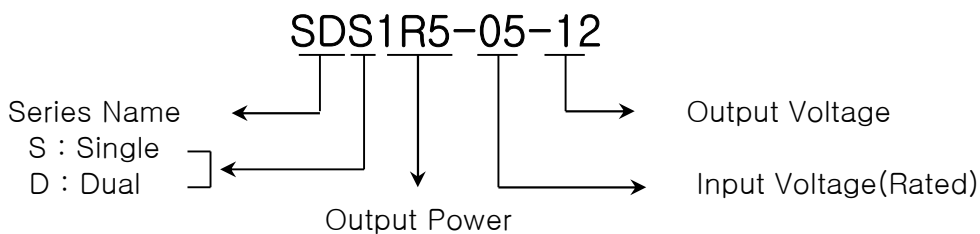

Pin assignments & Function

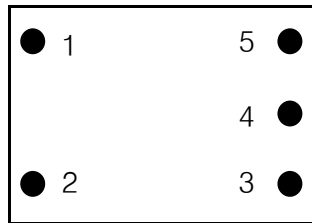

<Top View>

- Single Output Name & Function

PIN No.	NAME	FUNCTION
1	+Vin	Positive terminal for Vin
2	-Vin	Negative terminal for Vin
3	TRM	Vout variation($\pm 10\%$) by external parts
4	-Vout	Negative terminal for Vout
5	+Vout	Positive terminal for Vout

- Dual Output Name & Function

PIN No.	NAME	FUNCTION
1	+Vin	Positive terminal for Vin
2	-Vin	Negative terminal for Vin
3	-Vout	Negative terminal for Vout
4	Com	The common ground of Vout
5	+Vout	Positive terminal for Vout

- Datasheet

1. Internal Circuit Architecture

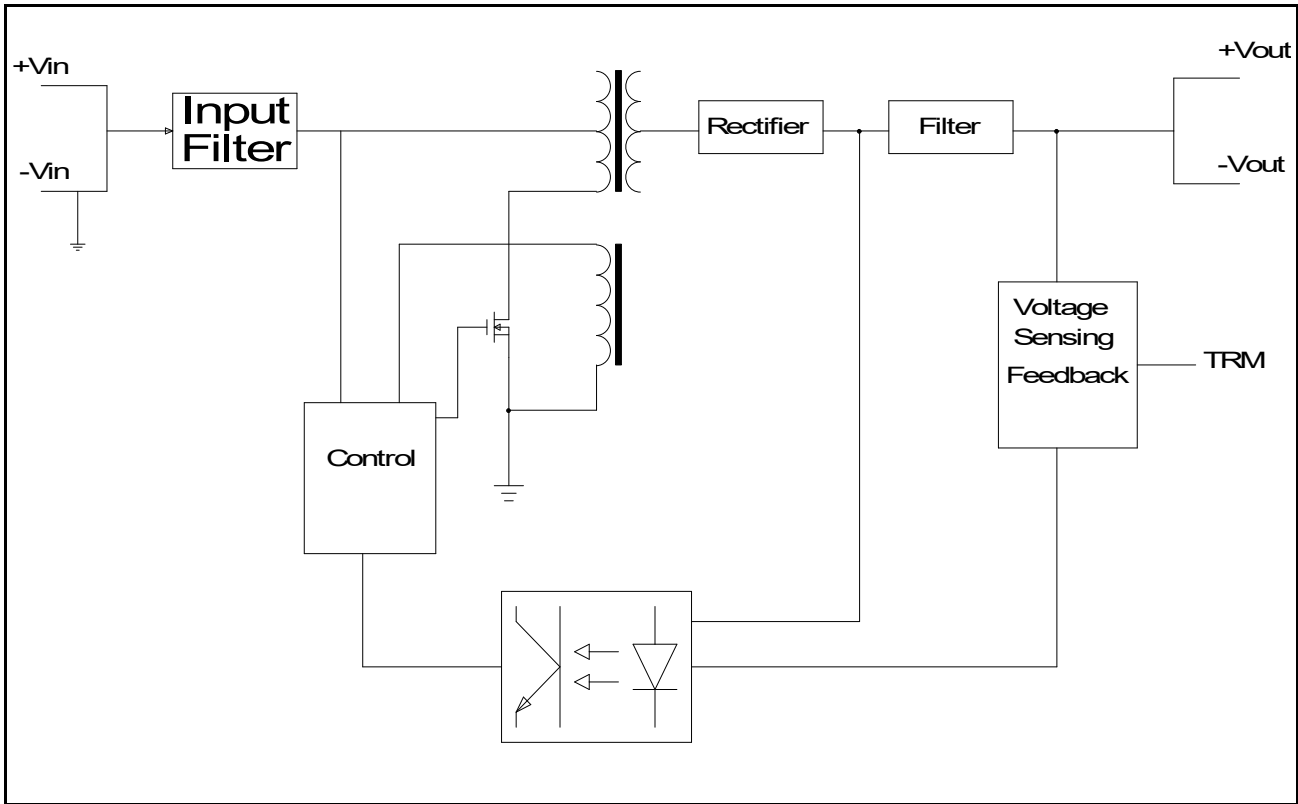

2. Maximum Ratings

Characteristics		Symbol	Min.	Typ.	Max.	Unit
Input Voltage Continuous	SDS1R5 - 05 - XX	Vin	4.5	-	9.0	VDC
	SDS1R5 - 12 - XX		9.0	-	18.0	
	SDS1R5 - 24 - XX		18.0	-	36.0	
	SDS1R5 - 48 - XX		36.0	-	76.0	
Operating Ambient Temperature		Ta	-40	-	85	°C
Storage Temperature		Tstg	-40	-	105	°C
Withstand Voltage			-	-	500	Vac

3. Electrical Characteristics

– Input Section

Ta : 25°C, Vin : Typical Input Voltage

Characteristics		Symbol	Min.	Typ.	Max.	Unit
Operating Voltage Range	SDS1R5 – 05 – XX	Vin	4.5	5.0	9.0	VDC
	SDS1R5 – 12 – XX		9.0	12.0	18.0	
	SDS1R5 – 24 – XX		18.0	24.0	36.0	
	SDS1R5 – 48 – XX		36.0	48.0	76.0	
Maximum Input Current (Vin : rated, Io : 100%)	SDS1R5 – 05 – XX	Iin		0.385		A
	SDS1R5 – 12 – XX			0.160		
	SDS1R5 – 24 – XX			0.078		
	SDS1R5 – 48 – XX			0.038		
Maximum No Load Input Current (Vin : rated)	SDS1R5 – 05 – XX			60		mA
	SDS1R5 – 12 – XX			25		
	SDS1R5 – 24 – XX			10		
	SDS1R5 – 48 – XX			5		

– Output Section

Ta : 25°C, Vin : Minimum, Typical, Maximum Input Voltage

Characteristics		Symbol	Min.	Typ.	Max.	Unit
Output Voltage Accuracy		Vo	–	–	±2	%
Regulation	Line Regulation (From min. Vin to max. Vin, constant load)		–	–	±0.5	%
	Load Regulation (From no load to maximum load)		–	–	±1	%
Output Ripple and Noise (Vin : Rated, Io : Max., BW : 20MHz, use the external capacitor(1uF) between +Vo and -Vo)		mVp-p	–	–	1% of Vout	mV (peak to peak)

Characteristics		Symbol	Min.	Typ.	Max.	Unit
Output Current	SDS1R5 - XX - 3R3	I _o	-	-	0.4	A
	SDS1R5 - XX - 05		-	-	0.3	
	SDS1R5 - XX - 12		-	-	0.13	
	SDS1R5 - XX - 15		-	-	0.1	
Output Current Limit (OCP : Over Current Protection, recovers automatically)			105	-	-	%
Dynamic Load Response (V _{in} : rated, I _o : from 50% to 100%, from 100% to 50%, BW : 20MHz, Freq. : 100Hz, Duty : 0.5, Tr/Tf : 100us use the external capacitor(1uF) between +Vo and -Vo)			-	-	3% of V _{out}	mV (peak to peak)
Start - Up Time		T _{start}	-	-	10	ms
Turn - on Overshoot			-	-	5	%
Efficiency (V _{in} : Rated, I _o : Max.)	SDS1R5 - 05 - 3R3		-	73	-	%
	SDS1R5 - 05 - 05		-	78	-	
	SDS1R5 - 05 - 12		-	81	-	
	SDS1R5 - 05 - 15		-	81	-	
	SDS1R5 - 12 - 3R3		-	73	-	%
	SDS1R5 - 12 - 05		-	78	-	
	SDS1R5 - 12 - 12		-	81	-	
	SDS1R5 - 12 - 15		-	81	-	
	SDS1R5 - 24 - 3R3		-	75	-	%
	SDS1R5 - 24 - 05		-	80	-	
	SDS1R5 - 24 - 12		-	83	-	
	SDS1R5 - 24 - 15		-	83	-	
	SDS1R5 - 48 - 3R3		-	73	-	%
	SDS1R5 - 48 - 05		-	78	-	
	SDS1R5 - 48 - 12		-	81	-	
	SDS1R5 - 48 - 15		-	81	-	

4. Isolation Characteristics

Characteristics		Symbol	Min.	Typ.	Max.	Unit
Withstand Voltage (AC500V, 1minute)	Input – Output		–	–	500	Vac
	Input – Case		–	–	500	Vac
	Output – Case		–	–	500	Vac
Isolation Resistance (DC500V at 25°C and 70%RH)	Output – Case	Riso	100	–	–	MΩ

5. General Characteristics

Characteristics		Symbol	Min.	Typ.	Max.	Unit
Remote on / off control (CNT Pin, Negative Logic Module on : Logic Low or Short to –Vin Module off : Logic High or open)		CNT				
External Trim Adj. Range (TRM Pin, Vout variation by external parts)		TRM	–10	–	+10	%
Switching Frequency						kHz
MTBF (MIL-HDBK-217F)			9 x 10 ⁵			hrs
Dimension (W x H x L)			18.5 x 8.5 x 16.0			mm
Weight			–	3.3	–	grams

6. Environment

Characteristics		Symbol	Min.	Typ.	Max.	Unit
Operating Temperature Range		Ta	–40	–	85	°C
Operating Humidity (non Condensing)			5	–	95	%RH
Storage Temperature		Tstg	–40	–	105	°C

7. Characteristics Curves

Efficiency Curves

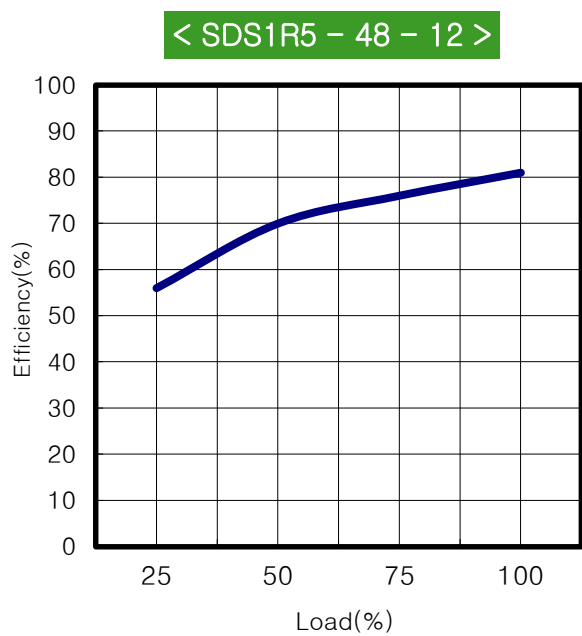
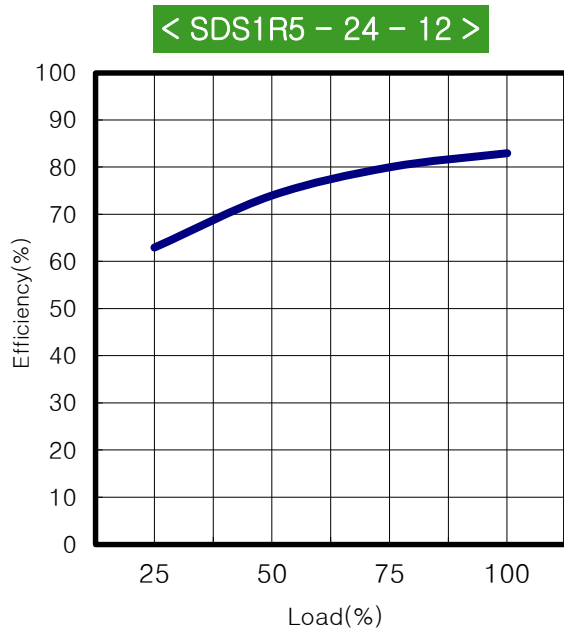
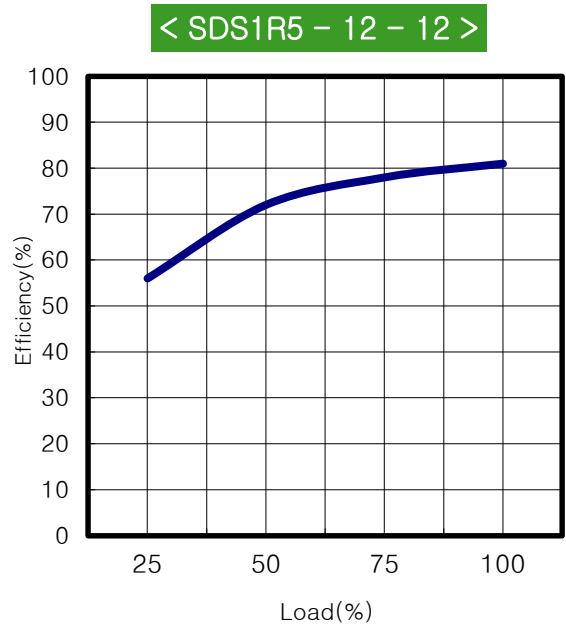
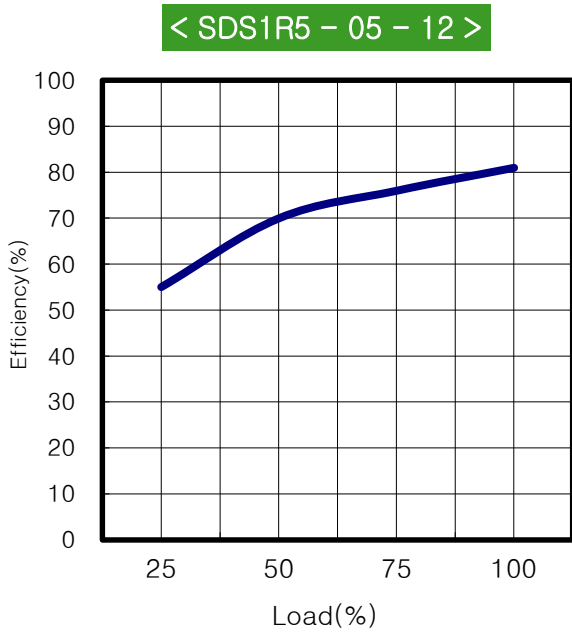

- Reliability Data

1. MTBF

Calculating Reliable Values of MTBF

Calculated based on part count reliability projection of MIL-HDBK-217F individual failure rates λg is given to each part and MTBF is calculated by the count of each part.

Method is :

$$MTBF = \frac{10^6}{\sum_{i=1}^{i=n} Ni(\lambda g \cdot \pi Q)_i} = \frac{10^6}{\lambda_{equip}} \quad [\text{hours}]$$

For a given equipment environment where :

λ_{equip} = Total equipment failure rate (Failures / 10⁶ Hours)

λg = Generic failure rate for the i th generic part (Failures / 10⁶ Hours)

πQ = Quality factor for the i th generic part ($\pi Q = 1$)

Ni = Qty of i th generic part

n = Number of different generic part categories in the equipment

	PART	Number	Failure Rate	Failure Rate
1	Logic IC	0	0.015	-
2	FET	2	0.012	0.0240000
3	Voltage Regulaor	1	0.002	0.0020000
4	Diode (Zener)	1	0.002	0.0020000
5	Diode (FRD)	0	0.069	-
6	Diode (SBD)	2	0.027	0.0540000
7	Bridge Diode	0	0.066	-
8	LED	0	0.00023	-
9	Varistor	0	0.0013	-
10	Photo-coupler	1	0.07	0.0700000
11	Thyristor	0	0.0022	-
12	Elec.- Cap.	0	0.019	-
13	Ceramic Cap.	5	0.026	0.1300000
14	MLCC	3	0.053	0.1590000
15	Choke coil	2	0.00022	0.0004400
16	Switching transformer	1	0.0042	0.0042000
17	Line Filter	0	0.0044	-
18	Resistor	13	0.0024	0.0312000
19	Resistor Variable	0	0.0024	-
20	Thermister	0	0.0019	-
21	Connertor	0	0.052	-
22	Soldering Point	32	0.0078	0.2496000
23	PCB	1	0.37	0.3700000
24	Fuse	1	0.01	0.0100000
Total Equipment Failure Rate (λ_{equip})				1.1064400
MTBF = 10 ⁶ / λ_{equip} (F/T)				903,799.573
MTBF ≅ 900,000[Hours]				

2. Environmental Stress Test(EST)

The purpose of the environment stress test is to ensure reliability by setting in advance the following environment and verified.

- transport process and conservation status
- environmental change conditions that can be applied to the product from the process of the end-user

Test cycle consists of 10 segments(total 270 hours). Test results of all segments must meet the specifications. (refer to Fig.1 & Table1)

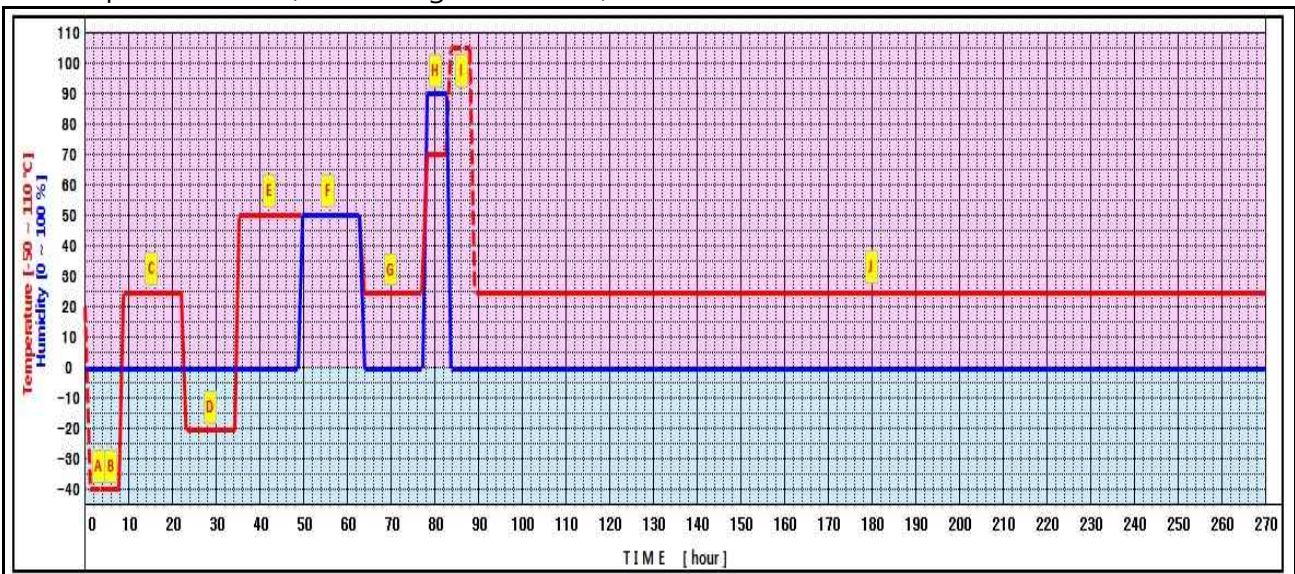

< Fig.1 : Test Cycle >

Segment	Time	Temp.	Humidity	Description	Input 'SW'
A	2 hours	-40°C	0%	Low temperature storage	off
B	4 hours	-40°C	0%	Low temperature operation	on
C	12 hours	25°C	0%	Room temperature operation	on
D	10 hours	-20°C	0%	Low temperature operation	on
E	12 hours	50°C	0%	High temperature operation	on
F	12 hours	50°C	50%	High-temperature & humidity operation	on
G	12 hours	25°C	0%	Room temperature operation	on
H	4 hours	70°C	90%	High-temperature & humidity operation	on
I	4 hours	105°C	0%	High temperature storage	off
J	189 hours	25°C	0%	Room temperature operation	on

< Table1 : Segment Description >

2.1. Environmental Stress Test Results

- a. Test Sample : SDS1R5-24-05
- b. 270 hours in one cycle test graph

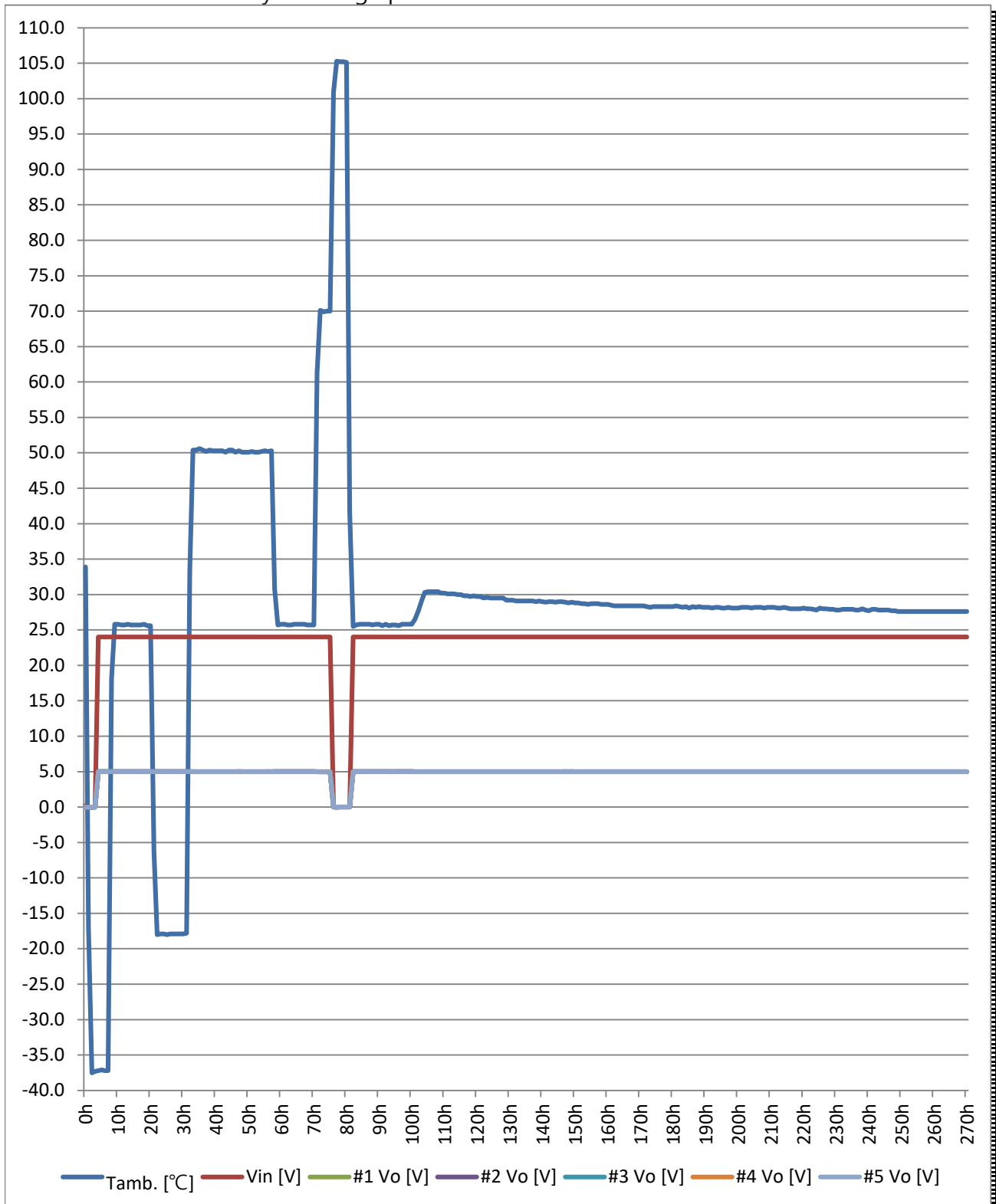

c. Characteristics test results (@ Input Voltage : 24VDC, Output Load : 0.24A(80% of Full load))

Segment	Test Time	T _{amb.} /Humi.	Output Voltage	Start up	Ripple / Noise [mVp-p]	Sapmle No.
A	3h	-40°C / 0%	4.97V	OK	12 / 30	# 1
			5.00V	OK	12 / 30	# 2
			5.02V	OK	12 / 33	# 3
			5.02V	OK	12 / 30	# 4
			5.00V	OK	12 / 36	# 5
B	7h	-40°C / 0%	4.98V	OK	10 / 25	# 1
			5.01V	OK	9 / 25	# 2
			5.02V	OK	10 / 25	# 3
			5.02V	OK	12 / 30	# 4
			5.00V	OK	10 / 28	# 5
C	10h	25°C / 0%	4.98V	OK	6 / 18	# 1
			5.00V	OK	6 / 18	# 2
			5.01V	OK	8 / 20	# 3
			5.01V	OK	6 / 16	# 4
			4.98V	OK	6 / 22	# 5
D	24h	-20°C / 0%	4.98V	OK	8 / 18	# 1
			5.00V	OK	8 / 18	# 2
			5.02V	OK	9 / 25	# 3
			5.01V	OK	9 / 20	# 4
			4.99V	OK	8 / 28	# 5
E	33h	50°C / 0%	4.98V	OK	6 / 16	# 1
			4.99V	OK	6 / 18	# 2
			5.00V	OK	6 / 23	# 3
			5.00V	OK	6 / 18	# 4
			4.97V	OK	6 / 20	# 5
F	48h	50°C / 50%	4.98V	OK	6 / 15	# 1
			4.99V	OK	6 / 18	# 2
			5.00V	OK	6 / 23	# 3
			5.00V	OK	6 / 15	# 4
			4.97V	OK	6 / 20	# 5
G	57h	25°C / 0%	4.98V	OK	6 / 12	# 1
			4.98V	OK	6 / 16	# 2
			5.00V	OK	6 / 20	# 3
			5.00V	OK	6 / 20	# 4
			4.97V	OK	6 / 20	# 5
H	72h	70°C / 90%	4.97V	OK	6 / 15	# 1
			4.97V	OK	6 / 20	# 2
			4.99V	OK	6 / 26	# 3
			4.99V	OK	8 / 25	# 4
			4.96V	OK	6 / 24	# 5
I	81h	25°C / 0%	4.98V	OK	6 / 15	# 1
			4.99V	OK	6 / 18	# 2
			5.01V	OK	8 / 23	# 3
			5.01V	OK	6 / 15	# 4
			4.98V	OK	6 / 20	# 5
J	270h	25°C / 0%	4.98V	OK	6 / 15	# 1
			4.98V	OK	6 / 18	# 2
			5.00V	OK	6 / 20	# 3
			5.00V	OK	6 / 15	# 4
			4.97V	OK	6 / 20	# 5
Test Result			Pass	Pass	Pass	

3. Main Components Δt Test

The purpose of the test is to ensure the reliability and margin by measuring the heating value of the main components.

3.1. SDS1R5-05-05 (@ 100% Load)

Test Point \ Test Condition	Vin : 4.5VDC		Vin : 5VDC	
	T _{amb.}	28.2°C	T _{amb.}	28.6°C
	T _c	Δt	T _c	Δt
FET	55.2°C	27.0°C	54.8°C	26.2°C
Trans Coil	54.0°C	25.8°C	53.5°C	24.9°C
Trans Core	54.0°C	25.8°C	54.0°C	25.4°C
Output Diode	58.1°C	29.9°C	58.0°C	29.4°C

4. Derating of Semiconductor

Compare T_{jmax}(maximum junction temperature) and T_j and is expressed as a percentage. T_j is the value calculated by the temperature of the case and the power dissipation and the thermal impedance.

- Measuring Components : FET, Rectifier diode
- Calculating method of derating ratio

$$\text{Derating Ratio} = \frac{T_j}{T_{j(max)}} \times 100 \text{ [%]}$$

$$T_j = T_c + (R_{\theta(j-c)} \times P_d)$$

T_c : Case Temperature

R_{θ(j-c)} : Thermal impedance between junction and case

P_d : Power dissipation

4.1. SDS1R5-05-05

Components \ Condition	Vin : 4.5VDC Load : 100%		T _{amb.} : 50°C
Q1 (FET)	T _{j(max)} : 150 °C	P _d : 0.07 W	Derating Ratio = 52.7%
	R _{θ(j-c)} : 30 °C/W	T _j = 79.1 °C	
	T _c : 77.0°C		
D4 (Rectifier Diode)	T _{j(max)} : 150 °C	P _d : 0.14 W	Derating Ratio = 59.8%
	R _{θ(j-c)} : 70 °C/W	T _j = 89.7 °C	
	T _c : 79.9°C		

5. Abnormal Test

Page 31 of 31
Report Reference No.: ITYA0703708



Clause	Requirement – Test					Result – Remark	Verdict
5.3	TABLE: fault condition tests						P
	ambient temperature (°C)					22 °C	—
	model/type of power supply					SDS1R5, SDS3	—
	manufacturer of power supply					Open Digital Power	—
	rated markings of power supply					5 – 48Vd.c.	—
component No.	fault	test voltage (V)	test time	fuse No.	fuse current (A)	result	
Reverse input	-	5/12/24/48	10 min	F1	3 - 1A	Immediately fuse(F1) opened. No hazard.	
C1	s/c	5/12/24/48	1 sec	F1	3 - 1A	Immediately fuse(F1) opened. No hazard.	
PC1 #3-4	s/c	5/12/24/48	10 min	F1	3 - 1A	Immediately output shutdown. No hazard.	
PC1 #-12	s/c	5/12/24/48	1 sec	F1	3 - 1A	Immediately fuse(F1) opened. No hazard.	
Output	s/c	5/12/24/48	30 min	F1	3 - 1A	Immediately output shutdown. No hazard.	
Q1 # 1-2	s/c	5/12/24/48	1 sec	F1	3 - 1A	Immediately fuse(F1) opened. No hazard.	
T1 # 1-5	s/c	5/12/24/48	30 min	F1	3 - 1A	Normal operation. No hazard.	
T1 # 3-5	s/c	5/12/24/48	30 min	F1	3 - 1A	Normal operation. No hazard.	
T1 # 1-7	s/c	5/12/24/48	30 min	F1	3 - 1A	Normal operation. No hazard.	
supplementary information							
s/c: short circuit, #: pin No.,							

Note Before placing the products in the different countries the manufacturer has to guarantee that:

1. Operating instructions and warnings are written in an accepted language of the certain country.
2. The equipment is in compliance with the national standards of the certain country.

Test Report EN/IEC 60950-1b Rev. 00 / 2003-04

- Application Sheet

1. Basic Connection

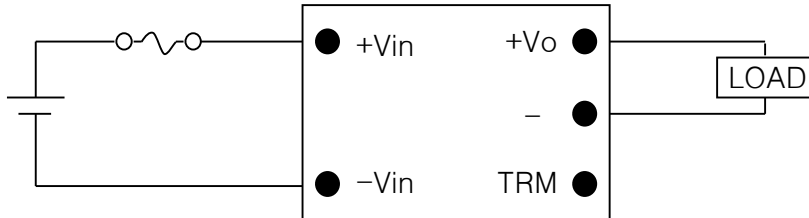

2. Input Section

- Input fuse

In order to comply with safety requirements, SDS series has a fuse(Slow Blow Type) built in.

	SDS1R5 Series	SDS3 Series	SDS6 Series	SDS10 Series
5V	2A	3A	5A	6A
12V	1A	2.5A	2.5A	4A
24V	1A	1A	2A	2.5A
48V	1A	1A	1.5A	2A

- Unstable Input

Input voltage is comprised of both the DC voltage(average rectified voltage)and the peak to peak ripple voltage. Peak to peak ripple voltage should be minimized so that the input voltage is within the standard input voltage range as follows.

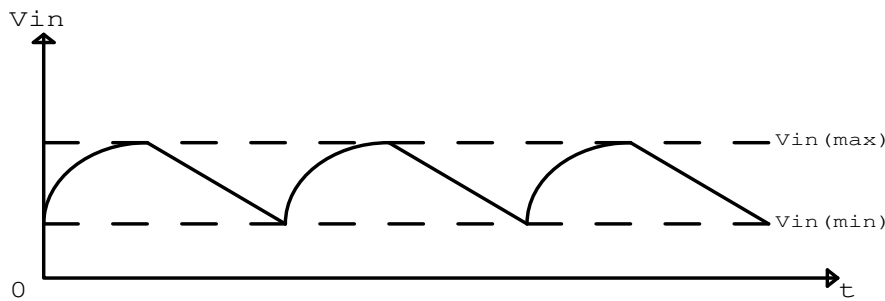

< Unstable Input >

- Battery Input

When using a battery as the input power supply, make sure that the maximum and minimum input voltage do not away out of the standard input voltage range.

- Input Reverse-polarity voltage protection

Accidently reversing the input connections could damage the module. Thus. If the connections may be accidentally reversed. Use a protective diode and an input fuse as shown below.

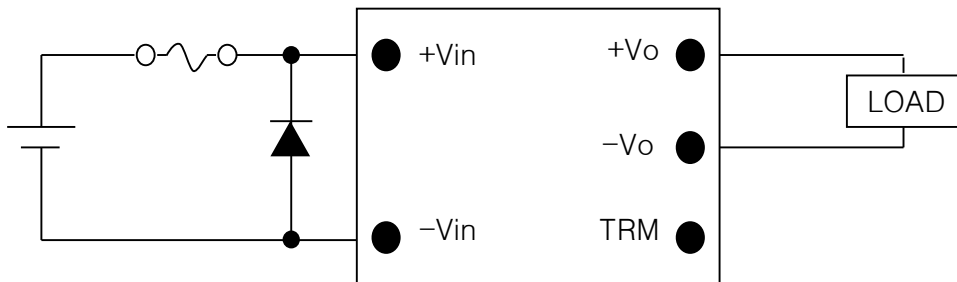

- Remote On/Off Control(CNT) (Except SDS1R5 Series)

Without switching the input on/off, the output can be enabled and disabled using this function. This function is useful for sequence control when building multiple output power supplies. This control circuit is on the input side using the CNT pin. Ground of CNT pin is the input -V terminal. When not using this function, short CNT to input -V terminal.

CNT level for -Vin		OUTPUT
Low level	Short to -Vin	ON
High level	Open	OFF

< Negative Logic on/off Control >

3. Output Section

- Output Ripple and Noise Measurement Method

The measurement for output ripple and noise are based on normal probe with 20MHz bandwidth scope. Upon measurement of the ripple voltage, make sure that the scope probe leads are not too long. If a precise measurement can be made, the noise occurs from circumference must be reduced.

- Line Regulation

The line regulation means to the change in output voltage when the input voltage is varied within the input voltage range, at constant load and constant ambient temperature. The measurement point for the input and output voltage are $\pm V_{in}$ pins, $\pm V_{out}$ pins respectively.

- Load Regulation

The load regulation means to the change in output voltage when the load is changed from minimum load to maximum load, at constant input voltage and constant ambient temperature. The measurement point for the input and output voltage are $\pm V_{in}$ pins, $\pm V_{out}$ pins respectively.

- Output Voltage adjustment (TRM)

The output voltage can be varied within $\pm 10\%$ of the standard output voltage when use the external parts-resistors and variable resistor.

External Resistors :

Resistance tolerance $\pm 5\%$

Variable Resistor(VR) :

Total resistance toloatace $\pm 20\%$

Remaining Resistance : Value less than 1%

V_o	R1	R2	VR
3.3V	1.5k Ω	680 Ω	1k Ω
5V	1k Ω	680 Ω	1k Ω
12V	3.9k Ω	680 Ω	1k Ω
15V	5.6k Ω	750 Ω	1k Ω
$\pm 12(24V)$	12k Ω	1k Ω	1k Ω
$\pm 15(30V)$	15k Ω	1k Ω	1k Ω

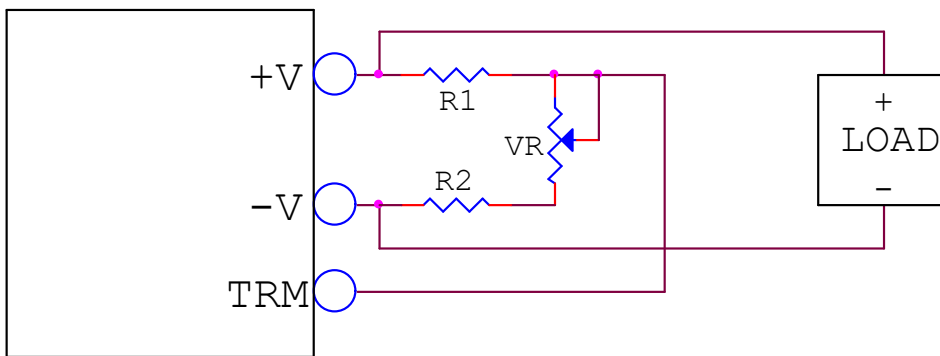

< Trim Method >

- Over Current Protection

The SDS series is built into an OCP(Over Current Protection) circuit. When the OCP triggers, the output voltage will be fall. If overload condition is removed, the output will automatically recover.

4. Operation Method

Parallel Operation

The module can be operated parallel connection. Refer to diagram as shown below.

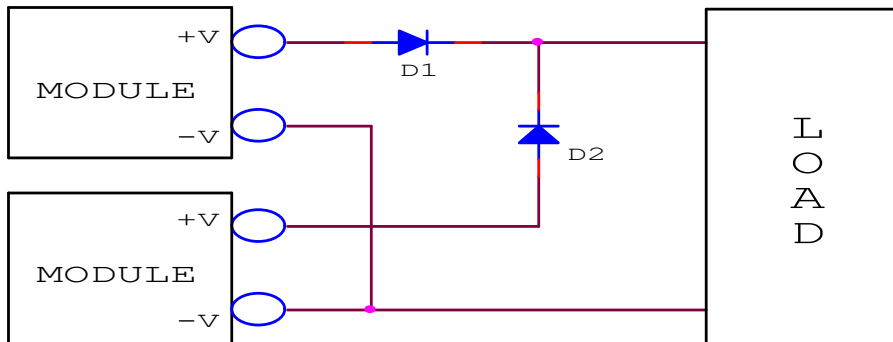

Please, you must consider both reverse voltage and forward current of diode, when you choose a diode.

Maximum reverse voltage(V_{rm}) : $V_{rm} > 1.5 \times V_o$

Forward current(I_f) : $I_f > 3 \times I_o$

Also, design a heatsink according to power loss at diode. If you want to reduce power loss, use a schottky barrier diode.

Power loss = $V_f(\text{forward voltage}) \times I_o(\text{output current})$

Series Operation

Series operation is available by connecting the outputs of two or more module as shown below.

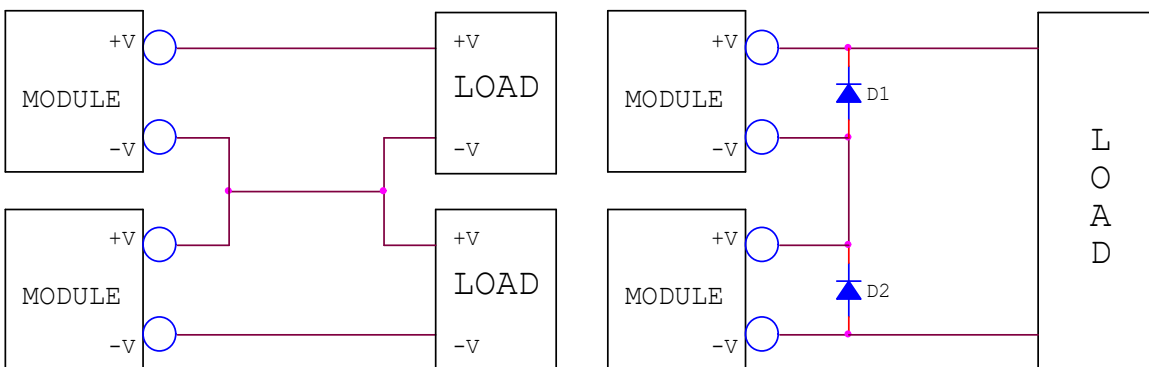

< A. General Series Operation >

< B. Complemental Series Operation >

Please, you must consider both reverse voltage and forward current of diode, when you choose a diode.

Maximum reverse voltage(V_{rm}) : $V_{rm} > 1.5 \times V_o$

Forward current(I_f) : $I_f > 3 \times I_o$

Also, design a heatsink according to power loss at diode. If you want to reduce power loss, use a schottky barrier diode.

Power loss = $V_f(\text{forward voltage}) \times I_o(\text{output current})$

5. Environment

- Temperature

Operation Temperature

The range of ambient temperature in °C over which a module can be operated safely at either rated or derated output power. Refer to derating curve as shown below.

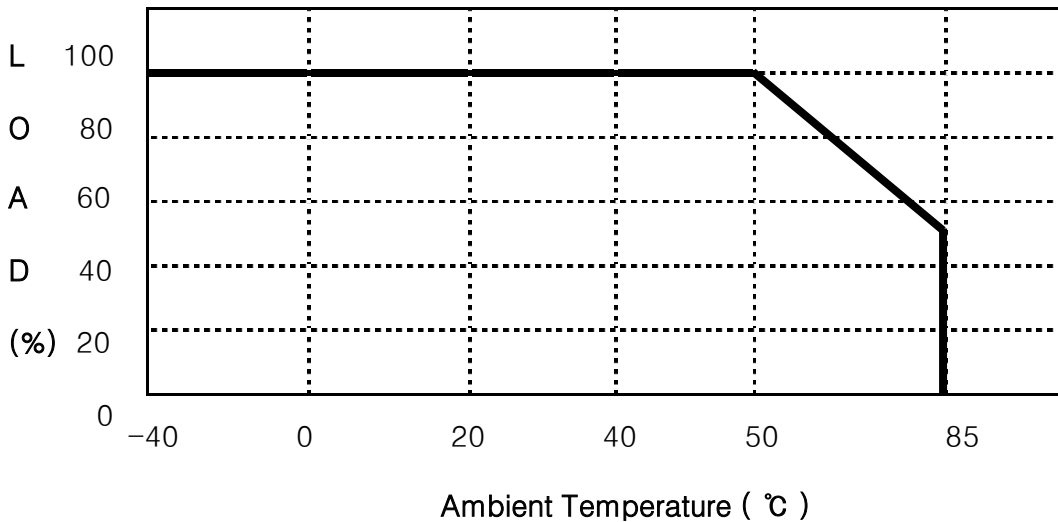

※ Operating Temperature Range : From -40°C to 85°C

< Derating Curve >

Storage Temperature

The range of ambient temperature in °C over which a module may be stored long term without damage. The storage temperature range is from -40°C to 105°C.

- Humidity

Operation Humidity

The range of ambient humidity in % over which a module can be operated safely at either rated or derated output power. Refer to derating curve as shown below. The operating humidity range is from 5% to 95%RH.

Storage Humidity

The range of ambient humidity in % over which a module may be stored long term without damage. The storage humidity range is from 5% to 95%RH.

6. Isolation

Isolation Resistance

The electrical separation between input and output of a module by means of the power transformer. The isolation resistance is a function of materials and spacings employed throughout the module. Please don't test with a voltage above standard voltage for the Isolation Resistance Test.

< INPUT - OUTPUT >

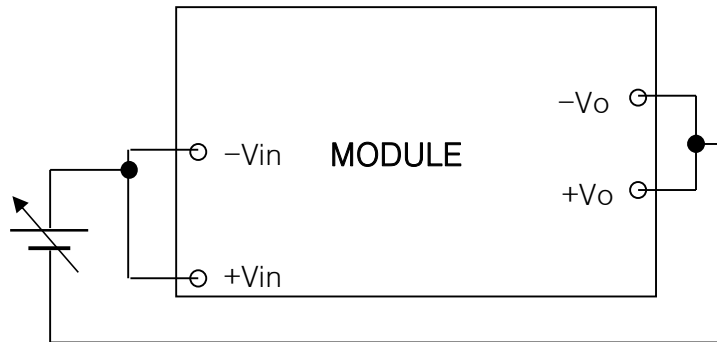

500VDC, 100MΩ

< INPUT - Case >

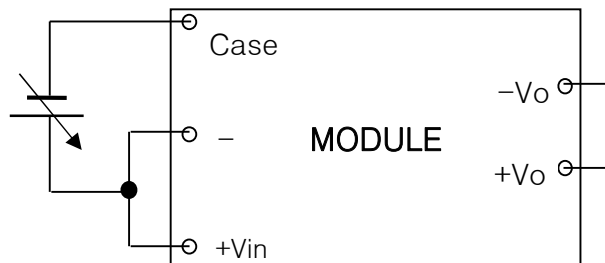

500VDC, 100MΩ

< OUTPUT - FRG >

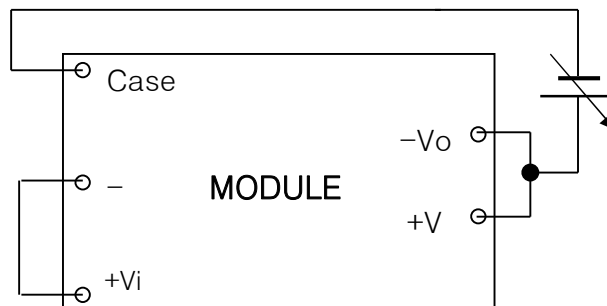

500VDC, 70MΩ

Withstand Voltage

For the withstand voltage test, the applied voltage must be increased gradually from zero to the testing value, and then decreased gradually at shut down. Especially stay away from use of a timer. Where a pulse of several times the applied voltage can be generated.

< INPUT - OUTPUT >

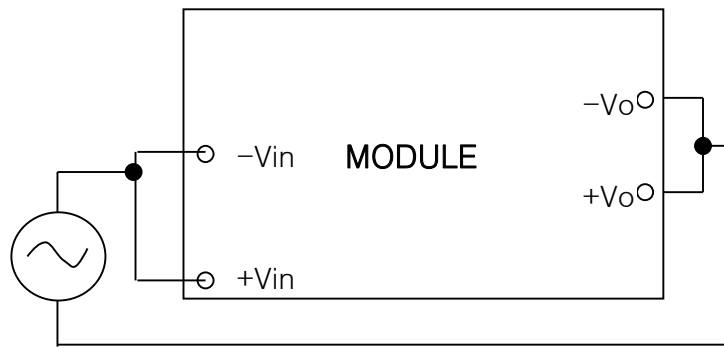

500VAC (10mA) 1minute

< INPUT - FRG >

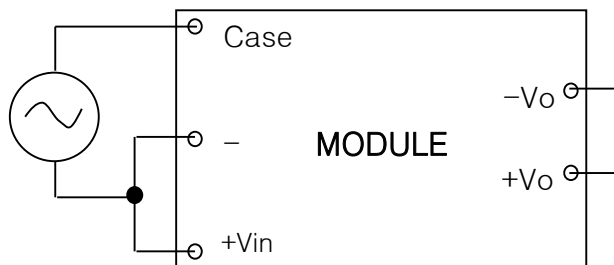

500VAC (10mA) 1minute

< OUTPUT - FRG >

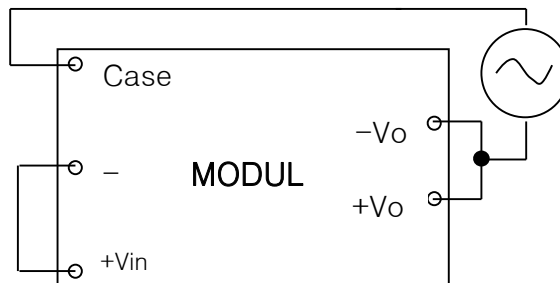

500VAC (10mA) 1minute

7. Outline Dimensions <Unit : mm (inch)>

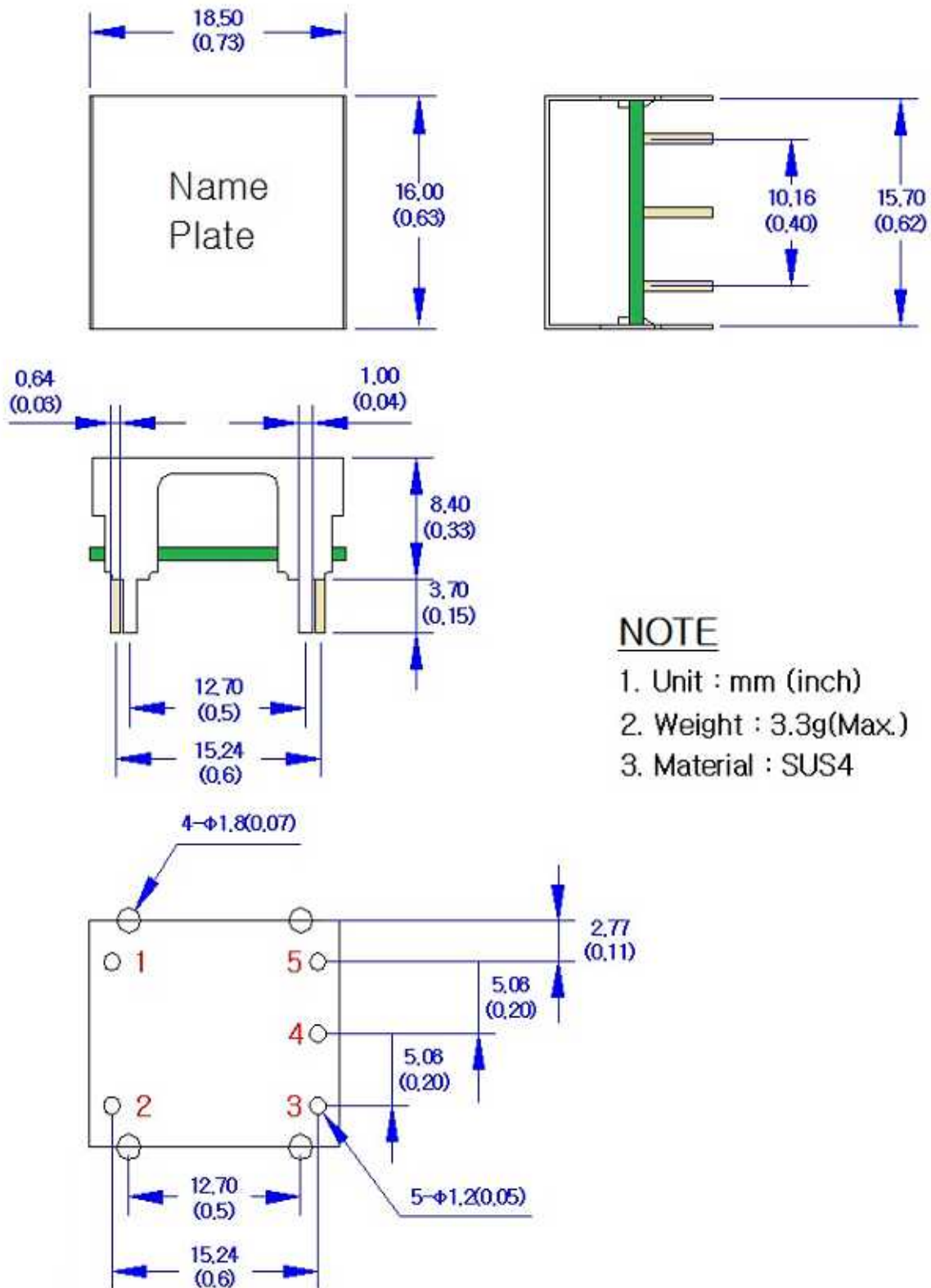

NOTE

1. Unit : mm (inch)
2. Weight : 3.3g(Max.)
3. Material : SUS4