

LCD Module Specification

Model No.: LT101A-03ACT

10.1", 1024 (RGB) x 600 PIXELS TFT LCD MODULE
With Capacitive Touch Panel

Table of Contents

1. BASIC SPECIFICATIONS.....	2
2. ABSOLUTE MAXIMUM RATINGS	4
3. ELECTRICAL CHARACTERISTICS	5
4. ELECTRO-OPTICAL CHARACTERISTICS.....	10
5. DIMENSIONAL OUTLINE	11
6. PRECAUTIONS FOR USE OF LCD MODULE.....	12

RECORD OF REVISION

Rev.	Date	Page	Item	Description
0.1	2020/10/12	-	-	New release

1. BASIC SPECIFICATIONS

1.1 Features

Item	Specifications	Unit
Screen Size	10.1 (Diagonal)	inch
Resolution	1024 (RGB) x 600	dot
Display Mode	Normally black, transmissive IPS TFT	-
Color Configuration	RGB-stripe	-
Color Depth	24-bit (RGB=888), 16.7M colors	-
Viewing Direction	6:00 o'clock (Gray scale inversion direction)	-
Outline Dimension (WxHxT)	235.0 x 143.0 x 5.0	mm
Viewing Area (WxH)	226.4 x 128.7	mm
Active Area (WxH)	222.72 x 125.28	mm
Dot Pitch (WxH)	0.0725 x 0.2088	mm
Touch Panel	None	-
Weight	250	g
LCD Controller	HX8282-A + HX8696-A or equivalent	-
Interface Mode	Digital 24-bit parallel RGB	-
Power Supply (DVDD)	3.3	V

1.2 Block Diagram

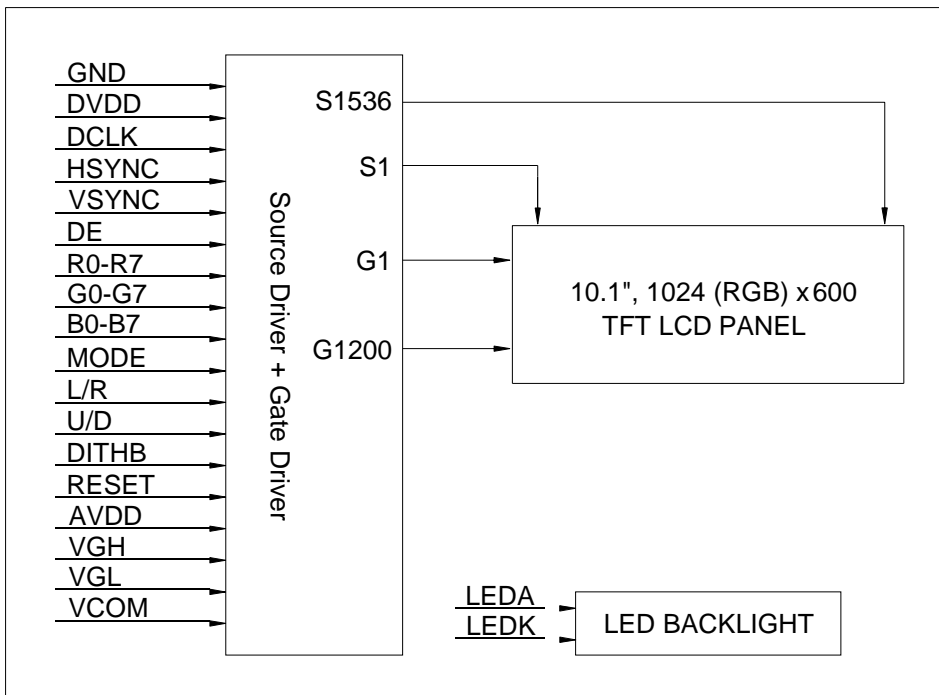

1.3 Terminals Functions

Pin No.	Symbol	I/O	Function
1 to 4	NC	-	No Connection
5	GND	P	Power ground
6	VCOM	I	Common voltage
7	DVDD	P	Power supply for digital circuit
8	MODE	I	DE/SYNC mode selection. Normally pull high. MODE=1: DE mode. MODE=0: SYNC mode.
9	DE	I	Data enable signal. Active "H".
10	VSYNC	I	Vertical sync signal. Negative polarity.
11	HSYNC	I	Horizontal sync signal. Negative polarity.
12	B7	I	Blue data (MSB)
13	B6	I	Blue data
14	B5	I	Blue data
15	B4	I	Blue data
16	B3	I	Blue data
17	B2	I	Blue data
18	B1	I	Blue data
19	B0	I	Blue data (LSB)
20	G7	I	Green data (MSB)
21	G6	I	Green data
22	G5	I	Green data
23	G4	I	Green data
24	G3	I	Green data
25	G2	I	Green data
26	G1	I	Green data
27	G0	I	Green data (LSB)
28	R7	I	Red data (MSB)
29	R6	I	Red data
30	R5	I	Red data
31	R4	I	Red data
32	R3	I	Red data
33	R2	I	Red data
34	R1	I	Red data
35	R0	I	Red data (LSB)
36	GND	P	Power ground
37	DCLK	I	Data clock. Latch data at falling edge.

Pin No.	Symbol	I/O	Function
38	GND	P	Power ground
39	L/R	I	Left/Right scanning direction selection L/R=1: Scanning from left to right L/R=0: Scanning from right to left
40	U/D	I	Up/Down scanning direction selection U/D=1: Scanning from down to up U/D=0: Scanning from up to down
41	VGH	P	Gate on voltage
42	VGL	P	Gate off voltage
43	AVDD	P	Power supply for analog circuit
44	RESET	I	Global reset pin. Normally pull high. Active "L" to enter reset state. Suggest connecting with an RC reset circuit for stability.
45	NC	-	No connection
46	VCOM	I	Common voltage
47	DITHB	I	Dithering function. Normally pull low. DITHB=1: Enable internal dithering function DITHB=0: Disable internal dithering function
48	GND	P	Power ground
49	NC	-	No Connection
50	NC	-	No Connection

I=Input; O=Output; P=Power

2. ABSOLUTE MAXIMUM RATINGS

Item	Symbol	Min.	Max.	Unit
Supply Voltage (Digital)	DVDD	-0.3	3.96	V
Supply Voltage (Analog)	AVDD	6.5	14.85	V
Supply Voltage (Gate on voltage)	VGH	-0.3	42.0	V
Supply Voltage (Gate off voltage)	VGL	VGH - 42.0	0.3	V
Input Voltage	VI	-0.3	DVDD + 0.3	V
LED Forward Current (Each LED)	IF	-	30	mA
Operating Temperature	Topr	-20	+70	°C
Storage Temperature	Tstg	-30	+80	°C

Cautions: Stresses above those listed as 'absolute maximum ratings' may cause permanent damage to the device. This is a stress rating only and functional operation of the device under these conditions is not implied. Exposure to maximum rating conditions for extended periods may affect device reliability.

3. ELECTRICAL CHARACTERISTICS

3.1 DC Characteristics for LCD (Ta=25°C)

Item	Symbol	Condition	Min.	Typ.	Max.	Unit
Supply Voltage	DVDD	Note 1	3.0	3.3	3.6	V
	AVDD	Note 1	12.0	12.2	12.4	V
	VGH	Note 1	19.0	22.0	25.0	V
	VGL	Note 1	-13.0	-10.0	-7.0	V
Input Signal Voltage	VCOM	Note 2	4.39	5.39	6.39	V
Input High Voltage	VIH		0.7DVDD	-	DVDD	V
Input Low Voltage	VIL		0	-	0.3DVDD	V
Supply Current	IDD	DVDD = 3.3V	-	7.0	14.0	mA
	IDDA	AVDD = 12.2V	-	28.0	40.0	mA
	IGH	VGH = 22.0V	-	0.5	1.0	mA
	IGL	VGL = -10.0V	-	3.0	8.0	mA

Note 1: It is suggested that users follow the circuits below to design DVDD, AVDD, VGH and VGL.

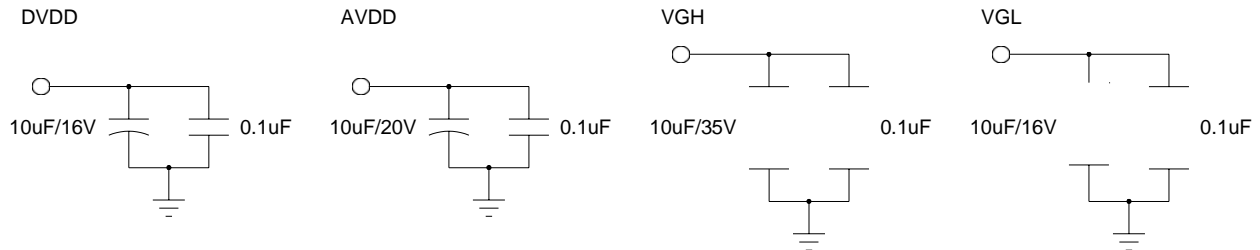

Note 2: Reference circuit for VCOM

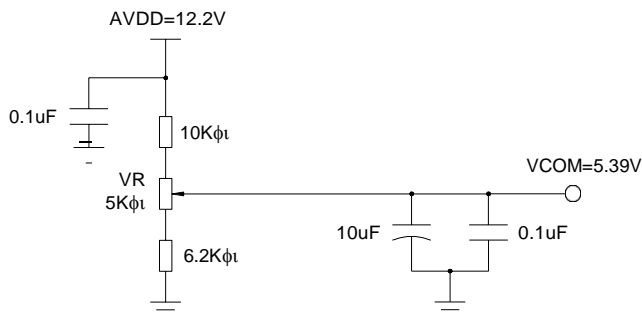

The typical VCOM is only a reference value. It must be optimized according to each TFT. Please use a VR and refer to the application circuit at left.

3.2 LED Backlight Characteristics (Ta=25°C)

Item	Symbol	Condition	Min.	Typ.	Max.	Unit
LED Forward Voltage	VLED	Note 1	8.5	8.8	9.1	V
LED Forward Current	ILED		240	300	330	mA
LED Life Time	-	Note 2	20,000	-	-	Hr

Note 1: The LED forward voltage is defined by the number of LED at Ta=25°C and ILED=300mA.

Note 2: The LED life time is defined as the module brightness decreases to 50% initial brightness at Ta=25°C and ILED=300mA. The LED life time could be decreased if operating ILED is larger than 300mA.

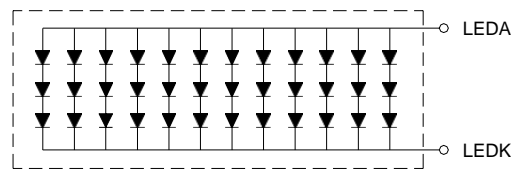

LED Backlight: 3 x 12 = 36 LEDS

3.3 Power Sequence

3.3.1 Power on Sequence

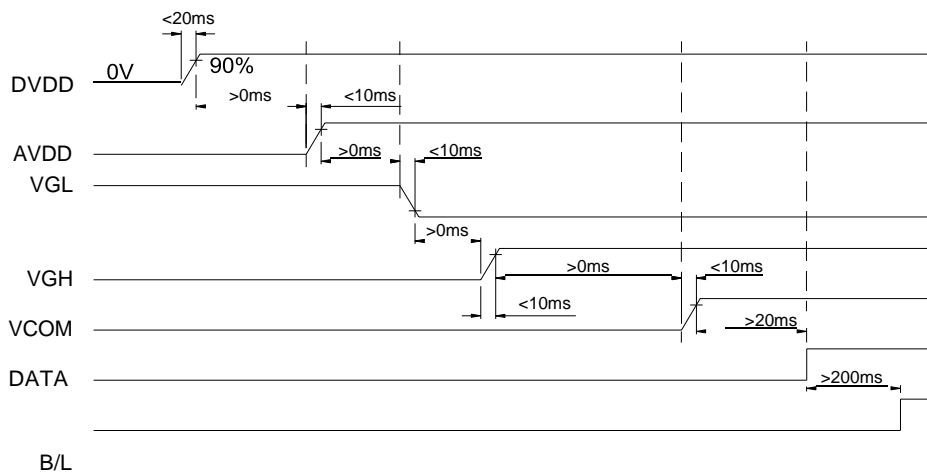

Power on sequence: DVDD → AVDD → VGL → VGH → VCOM → DATA → B/L

3.3.2 Power off Sequence

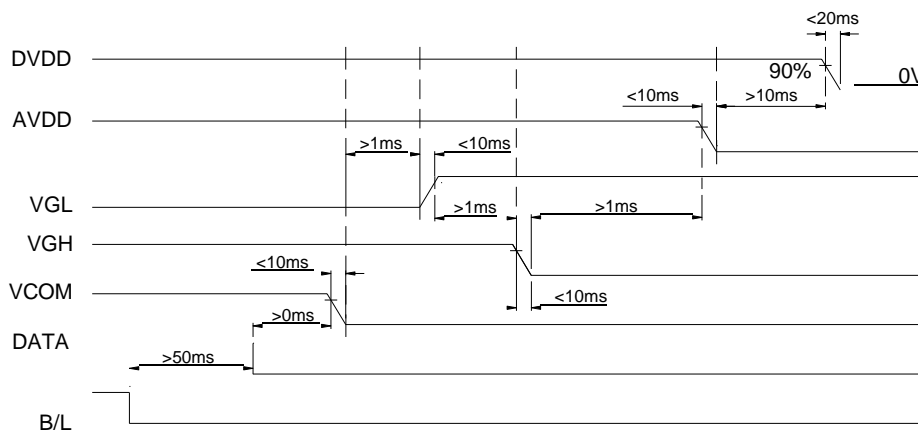

Power off sequence: B/L → DATA → VCOM → VGL → VGH → AVDD → DVDD

3.4 AC Characteristics (DVDD=3.3V, Ta=25°C)

Item	Symbol	Min.	Typ.	Max.	Unit
DCLK Pulse Duty	Tcwh	40	50	60	%
DCLK Period	Tclk	14	-	-	ns
VSYNC Setup Time	Tvst	5	-	-	ns
VSYNC Hold Time	Tvhd	5	-	-	ns
HSYNC Setup Time	Thst	5	-	-	ns
HSYNC Hold Time	Thhd	5	-	-	ns
Data Setup Time	Tdsu	5	-	-	ns
Data Hold Time	Tdhd	5	-	-	ns
DE Setup Time	Tdest	5	-	-	ns
DE Hold Time	Tdehd	5	-	-	ns

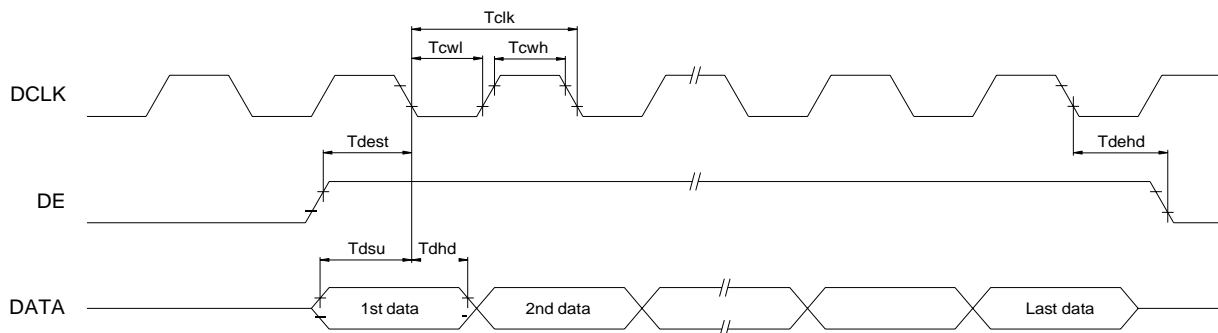
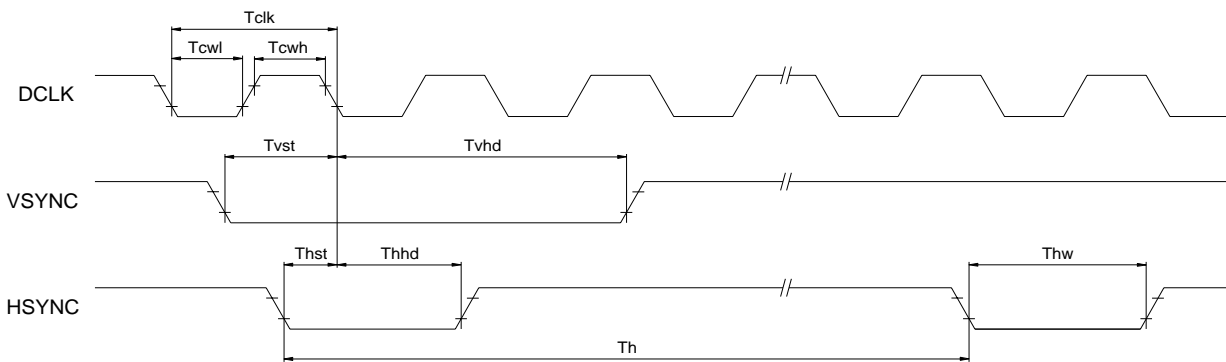

3.5 Input Signals Timing Characteristics (SYNC Mode)

Item	Symbol	Min.	Typ.	Max.	Unit
DCLK Frequency	Fclk	44.9	51.2	63	MHz
HSYNC Period	Th	1200	1344	1400	DCLK
HSYNC Display Period	Thdisp	-	1024	-	DCLK
HSYNC Back Porch	Thbp	160	160	160	DCLK
HSYNC Front Porch	Thfp	16	160	216	DCLK
HSYNC Pulse Width	Thw	1	-	140	DCLK
VSYNC Period	Tv	624	635	750	Th
VSYNC Display Period	Tvdisp	-	600	-	Th
VSYNC Back Porch	Tvbp	23	23	23	Th
VSYNC Front Porch	Tvfp	1	12	127	Th
VSYNC Pulse Width	Tvw	1	-	20	Th

Note: It is necessary to keep $Tvbp=23$ and $Thbp=160$ in SYNC mode. It's unnecessary to keep it in DE mode.

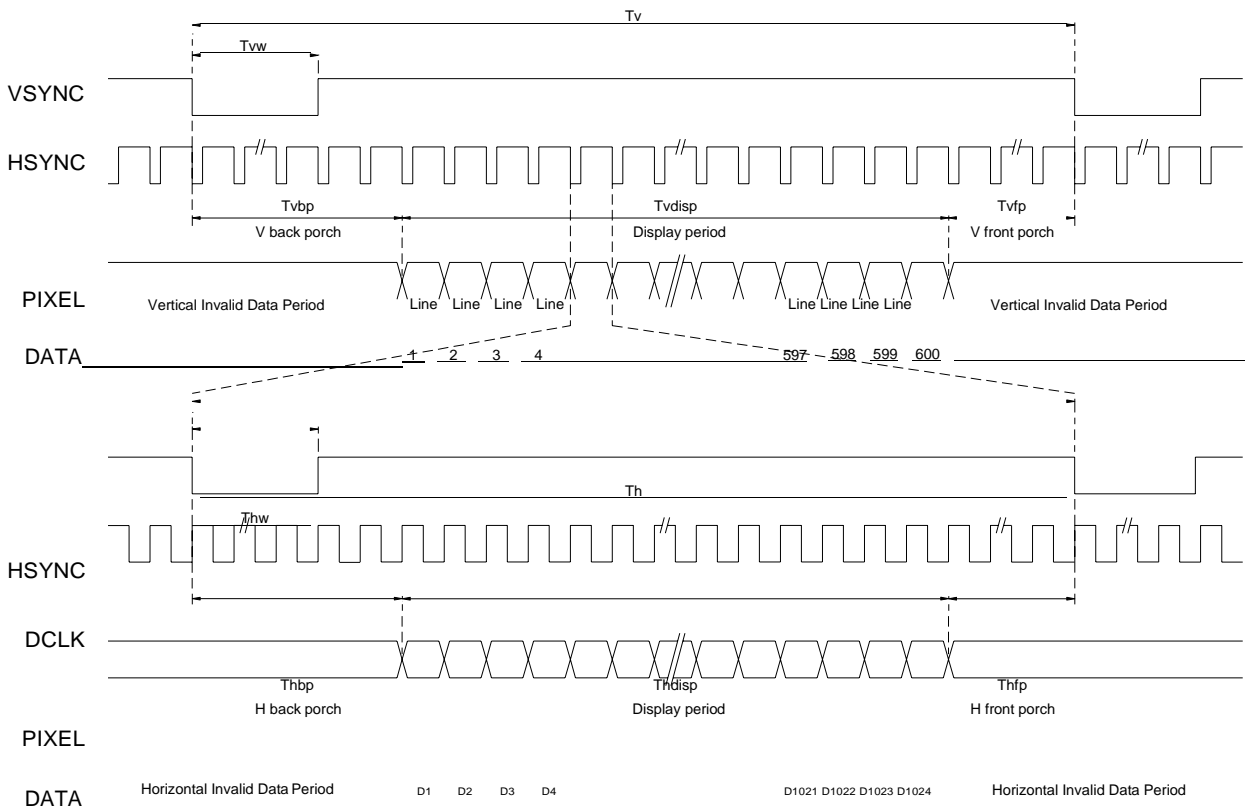

3.6 Input Signals Timing Characteristics (DE Mode)

Item	Symbol	Min.	Typ.	Max.	Unit
DCLK Frequency	Fclk	40.8	51.2	67.2	MHz
HSYNC Period	Th	1114	1344	1600	DCLK
HSYNC Display Period	Thdisp	-	1024	-	DCLK
DEH Blanking	Thb=Thbp+Thfp	90	320	376	DCLK
VSYNC Period	Tv	610	635	800	Th
VSYNC Display Period	Tvdisp	-	600	-	Th
DEV Blanking	Tvb=Tvbp+Tvfp	10	35	200	Th

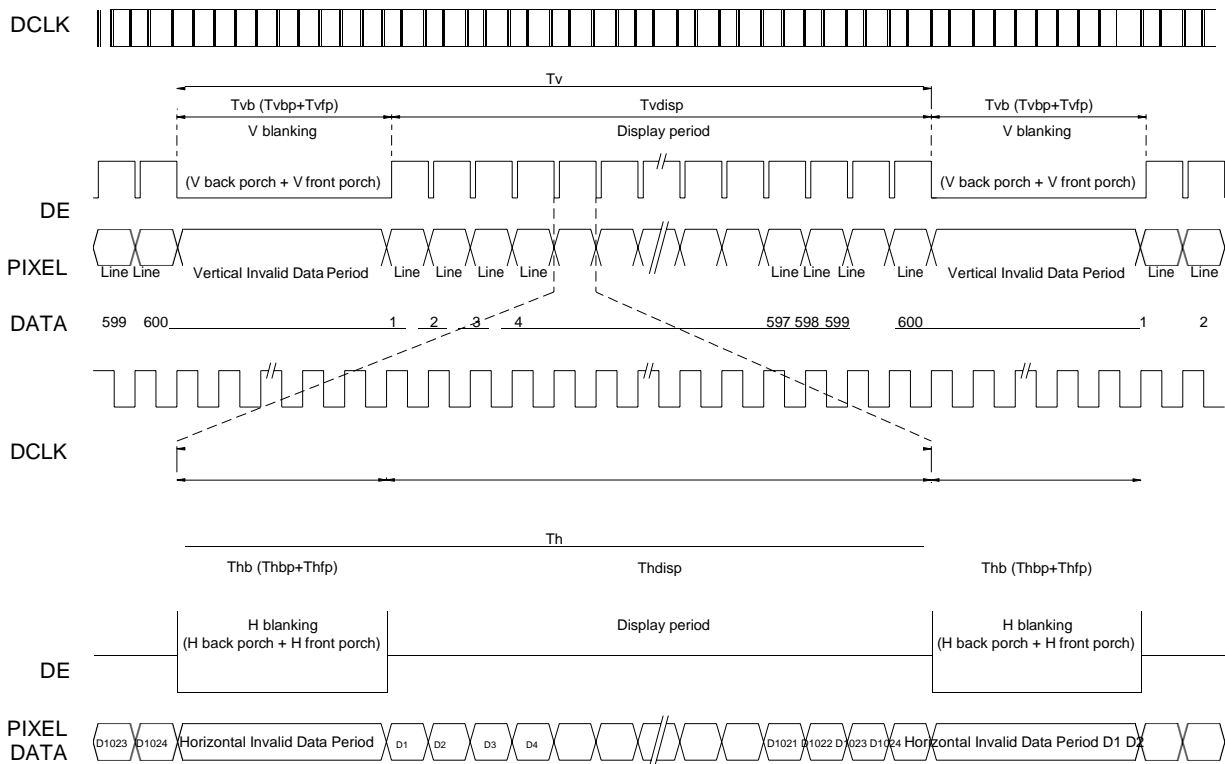

4. ELECTRO-OPTICAL CHARACTERISTICS (Ta=25°C)

Item	Symbol	Condition	Min.	Typ.	Max.	Unit	Note
Brightness of White	Bp	$\Theta=0^\circ$ $\Phi=0^\circ$	-	300	-	cd/m ²	1
Uniformity	ΔBp	ILED=300mA	70%	-	-	-	2
Viewing Angle	Hor	ΘR	80	-	-	deg.	3
		ΘL	80	-	-		
	Ver	ΘU	80	-	-		
		ΘD	80	-	-		
Contrast Ratio	Cr	$\Theta=0^\circ$ $\Phi=0^\circ$	-	800	-	-	4
Response Time	Ton + Toff		-	25	35	ms	5
Color Chromaticity	Wx		0.297	0.317	0.337	-	1, 6
	Wy	0.306	0.326	0.346	-		

Note 1: The optical characteristics should be measured by BM-7 in dark room after 15 minutes operation. The optical properties are measured at the center point of the LCD.

Note 2: $\Delta Bp = Bp(\text{Min.}) / Bp(\text{Max.}) \times 100 (\%)$
 Bp(Max.)=Maximum brightness in 9
 Bp(Min.)=Minimum brightness in 9

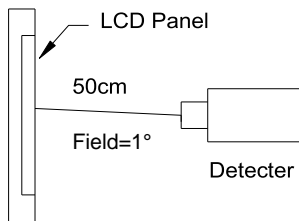

Note 3: Definition of Viewing Angle

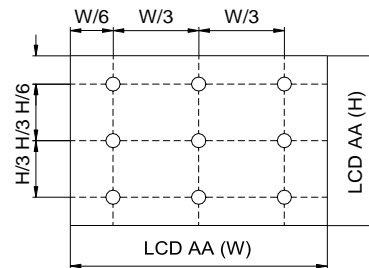

Note 5: Definition of Response Time

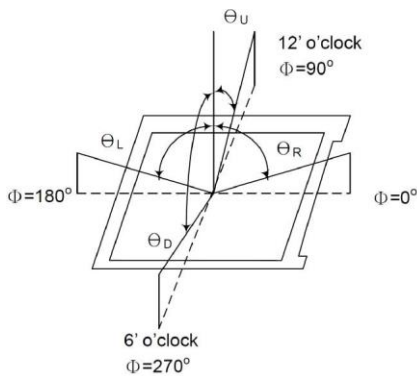

Note 4: Definition of Contrast Ratio

$$\text{Contrast Ratio (Cr)} = \frac{\text{Brightness measured when LCD on "White" State}}{\text{Brightness measured when LCD on "Black" state}}$$

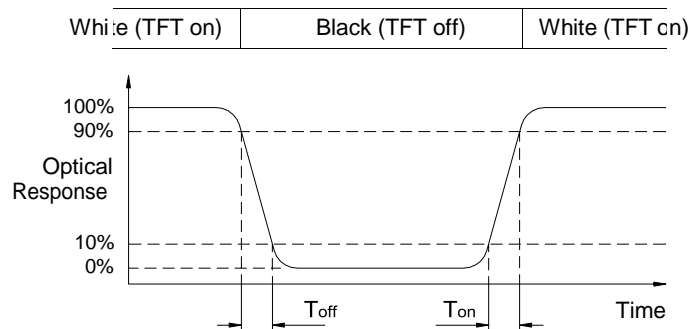

Note 6: Definition of color chromaticity (CIE1931)

Color coordinates is measured at the center point of the LCD with ILED=240mA and the LCD displays white.

5. DIMENSIONAL OUTLINE

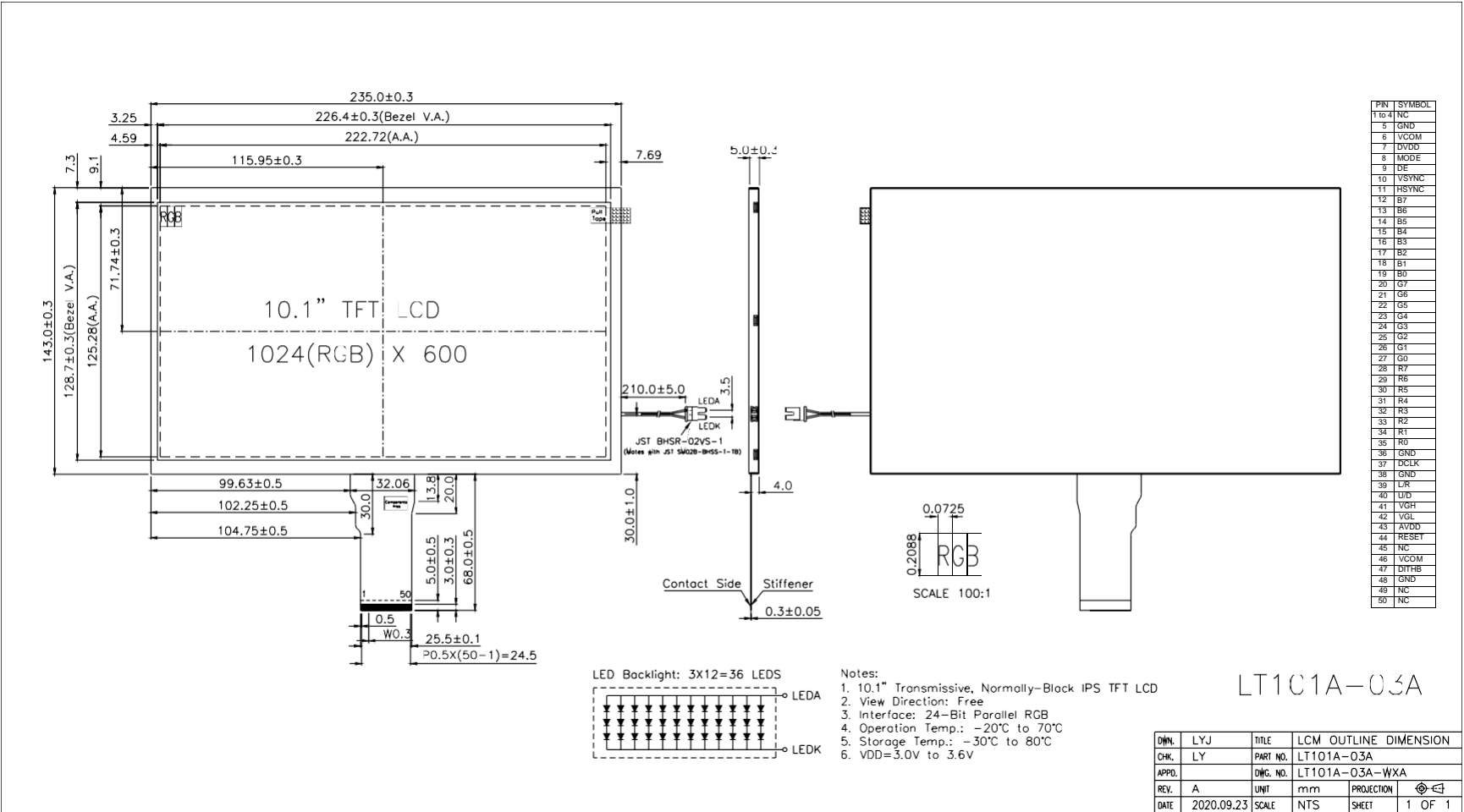

CHK.	LYJ	TITLE	LCM OUTLINE DIMENSION		
APPD.		PART NO.	LT101A-03A		
REV.	A	ENG. NO.	LT101A-03A-WXA		
DATE	2020.09.23	UNIT	mm	PROJECTION	①
		SCALE	NTS	SHEET	1 OF 1

FRONT VIEW

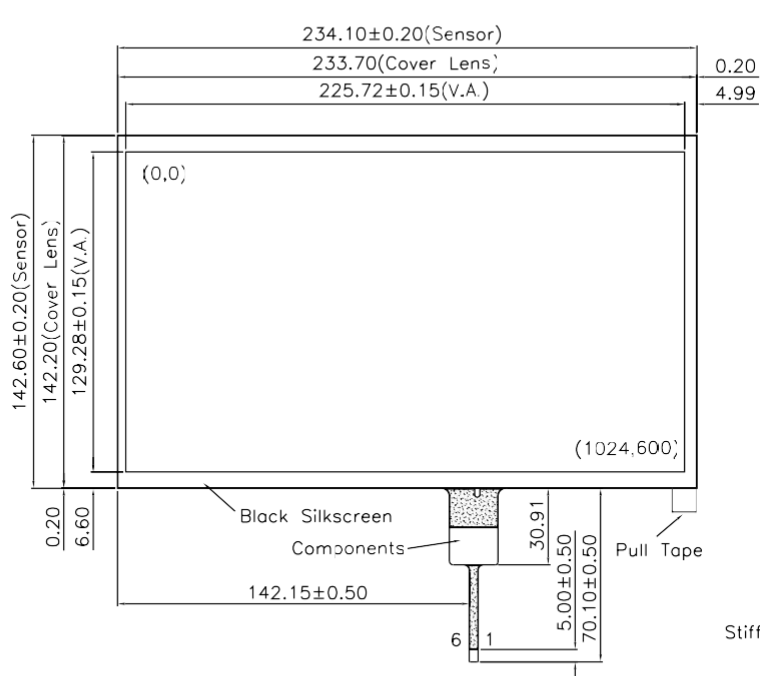

SIDE VIEW

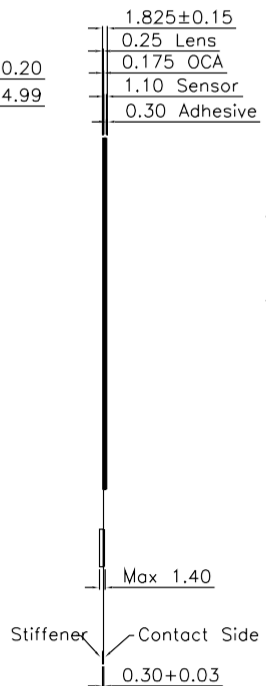

REAR VIEW

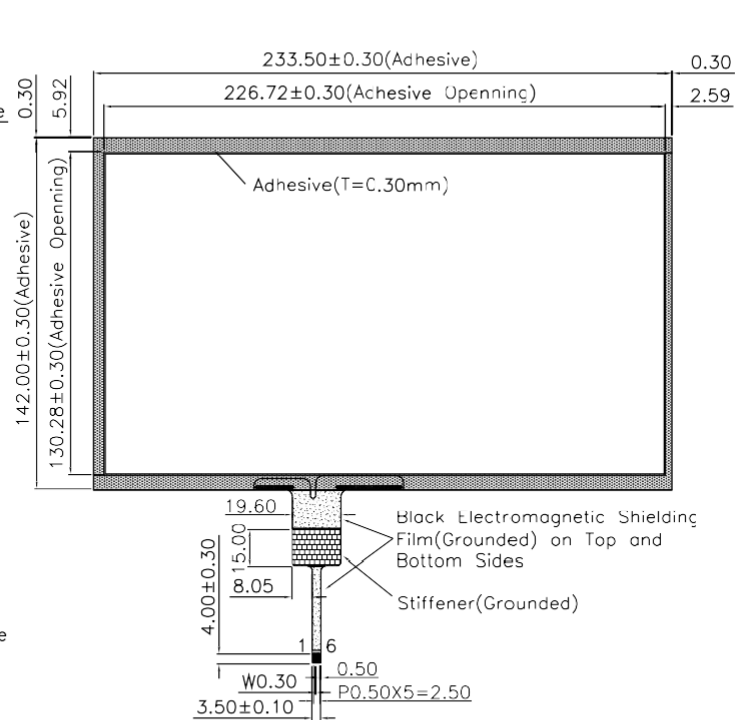

Specification:

1. Structure: PET(Lens)+Glass(Sensor)
2. IC: GT9271
3. VDD: 2.8V to 3.3V
4. Light Transmittance: 80%
5. Surface Hardness: 3H
6. Operating Temperature: -20° to +70°(≤90%RH)
7. Storage Temperature: -30° to +80°(≤90%RH)



6. PRECAUTIONS FOR USE OF LCD MODULE

6.1 Handling Precautions

- 1) The display panel is made of glass. Do not subject it to a mechanical shock by dropping it from a high place, etc.
- 2) If the display panel is damaged and the liquid crystal substance inside it leaks out, be sure not to get any in your mouth. If the substance comes into contact with your skin or clothes, promptly wash it off using soap and water.
- 3) Do not apply excessive force on the surface of display or the adjoining areas of LCD module since this may cause the color tone to vary.
- 4) The polarizer covering the display surface of the LCD module is soft and easily scratched. Handle this polarizer carefully.
- 5) If the display surface of LCD module becomes contaminated, blow on the surface and gently wipe it with a soft dry cloth. If it is heavily contaminated, moisten cloth with one of the following solvents.
 - Isopropyl alcohol
 - Ethyl alcoholSolvents other than those mentioned above may damage the polarizer. Especially, do not use the following:
 - Water
 - Ketone
 - Aromatic Solvents
- 6) When mounting the LCD module make sure that it is free of twisting, warping, and distortion. Distortion has great influence upon display quality. Also keep the stiffness enough regarding the outer case.
- 7) Be sure to avoid any solvent such as flux for soldering never stick to Heat-Seal. Such solvent on Heat-Seal may cause connection problem of heat-Seal and TAB.
- 8) Do not forcibly pull or bend the TAB I/O terminals.
- 9) Do not attempt to disassemble or process the LCD module.
- 10) NC terminal should be open. Do not connect anything.
- 11) If the logic circuit power is off, do not apply the input signals.
- 12) To prevent destruction of the elements by static electricity, be careful to maintain an optimum work environment.
 - Be sure to ground the body when handling the LCD module.
 - Tools required for assembly, such as soldering irons, must be properly grounded.
 - To reduce the amount of static electricity generated, do not conduct assembly and other work under dry conditions.
 - The LCD module is coated with a film to protect the display surface. Exercise care when peeling off this protective film since static electricity may be generated.

6.2 Storage Precautions

- 1) When storing the LCD module, avoid exposure to direct sunlight or to the light of fluorescent lamps and high temperature/high humidity. Whenever possible, the LCD module should be stored in the same conditions in which they were shipped from our company.
- 2) Exercise care to minimize corrosion of the electrodes. Corrosion of the electrodes is accelerated by water droplets or a current flow in a high humidity environment.

6.3 Design Precautions

- 1) The absolute maximum ratings represent the rated value beyond which LCD module can not exceed. When the LCD modules are used in excess of this rated value, their operating characteristics may be adversely affected.

- 2) To prevent the occurrence of erroneous operation caused by noise, attention must be paid to satisfy VIL, VIH specification values, including taking the precaution of using signal cables that are short.
- 3) The liquid crystal display exhibits temperature dependency characteristics. Since recognition of the display becomes difficult when the LCD is used outside its designated operating temperature range, be sure to use the LCD within this range. Also, keep in mind that the LCD driving voltage levels necessary for clear displays will vary according to temperature.
- 4) Sufficiently notice the mutual noise interference occurred by peripheral devices.
- 5) To cope with EMI, take measures basically on outputting side.
- 6) If DC is impressed on the liquid crystal display panel, display definition is rapidly deteriorated by the electrochemical reaction that occurs inside the liquid crystal display panel. To eliminate the opportunity of DC impressing, be sure to maintain the AC characteristics of the input signals sent to the LCD Module.

6.4 Others

- 1) Liquid crystals solidify under low temperatures (below the storage temperature range) leading to defective orientation or the generation of air bubbles (black or white). Air bubbles may also be generated if the LCD module is subjected to a strong shock at a low temperature.
- 2) If the LCD modules have been operating for a long time showing the same display patterns, the display patterns may remain on the screen as ghost images and a slight contrast irregularity may also appear. A normal operating status can be regained by suspending use for some time. It should be noted that this phenomenon does not adversely affect performance reliability.
- 3) To minimize the performance degradation of the LCD modules resulting from destruction caused by static electricity, etc., exercise care to avoid touching the following sections when handling the module:
 - Terminal electrode sections.
 - Part of pattern wiring on TAB, etc.