

SPECIFICATION



Product : Topview 5050 White SMD LED

Part No. : IWS-164-WXWF-S2

Date : 2009. 10. 26 Ver. 3.2

Proposed By	Checked By	Checked By	Checked By	Approval

Comment



ITSWELL Co., Ltd
58B-4L, 626-3 Gojan-dong, Namdong-gu, Incheon
405-817 KOREA
TEL:+82-32-813-1801, FAX:+82+32-816-1900
URL: <http://www.itswell.com>

Topview 1608 White LEDs

IWS-164-WXWF-S2



4. Absolute Maximum Ratings

Items	Symbols	Ratings	Unit
Operation Forward Current	I_F	30	mA
Peak Pulsed Forward Current*1	I_{PF}	100	mA
Operating Temperature Range	T_{OP}	-25 ~ 80	°C
Power Dissipation	T_D	93	mW
Reverse Current	I_R	50	uA
Storage Temperature Range	T_S	-30 ~ +85	°C
Soldering Temperature	T_{SOL}	260 ± 10	°C
Electro Static Discharge Forward	F_{ESD}	Max. 2KV	V
Electro Static Discharge Reverse	R_{ESD}	Min. 150V	V

*1 Duty ratio = 1/10, Pulse width = 0.1ms

5. Electrical & Optical Characteristics (Ta : 25°C)

Parameter	Symbol	Conditions	Min.	Typ.	Max.	Unit.
Forward Voltage	V_{F1}	$I_F = 5mA$	2.7	2.9	3.1	V
Forward Voltage	V_{F2}	$I_F = 1uA$	2.0	2.4	2.6	V
Reverse Current	I_R	$V_R = 5V$	-	-	50	uA
Luminous Intensity*2	I_V	$I_F = 5mA$	70	90	130	mcd
View Angle*3	2θ1/2	$I_F = 5mA$	110	120	130	Degrees
CIE Index*4	-	$I_F = 5mA$	-	x=0.270 y=0.260	-	-

*2 Luminous Intensity is tested by a tester calibrated by CAS 140B(CIE LED_B) and has an accuracy of 10%.

*3 Viewing angle is the angle until 50% of brightness measured from the front part of LED.

*4 CIE Index is tested by a tester calibrated by CAS 140B(CIE LED_B) and has an accuracy of 10%.

5.1 Luminous Intensity Rank

Rank	Luminous Intensity (mcd)
3	70 - 90
4	90 - 110
5	110 - 130

5.3 Forward Voltage Rank

Rank	Forward Voltage (V)
1	2.7 - 2.8
2	2.8 - 2.9
3	2.9 - 3.0
4	3.0 - 3.1

5.2 Chromaticity Coordinates Rank

Rank	CIE x, CIE y
W1-1	Refer to 5.2 in the next page
W1-2	
W2-1	
W2-2	

Topview 1608 White LEDs

IWS-164-WXWF-S2



5.2. Chromaticity Coordinates Rank ($I_F = 5 \text{ mA}$, $T_a = 25 \text{ }^\circ\text{C}$)

Rank W1-1				
x	0.250	0.265	0.285	0.270
y	0.240	0.270	0.270	0.240

Rank W1-2				
x	0.270	0.285	0.305	0.290
Y	0.240	0.270	0.270	0.240

Rank W2-1				
x	0.265	0.280	0.300	0.285
y	0.270	0.300	0.300	0.270

Rank W2-2				
x	0.285	0.300	0.320	0.305
y	0.270	0.300	0.300	0.270

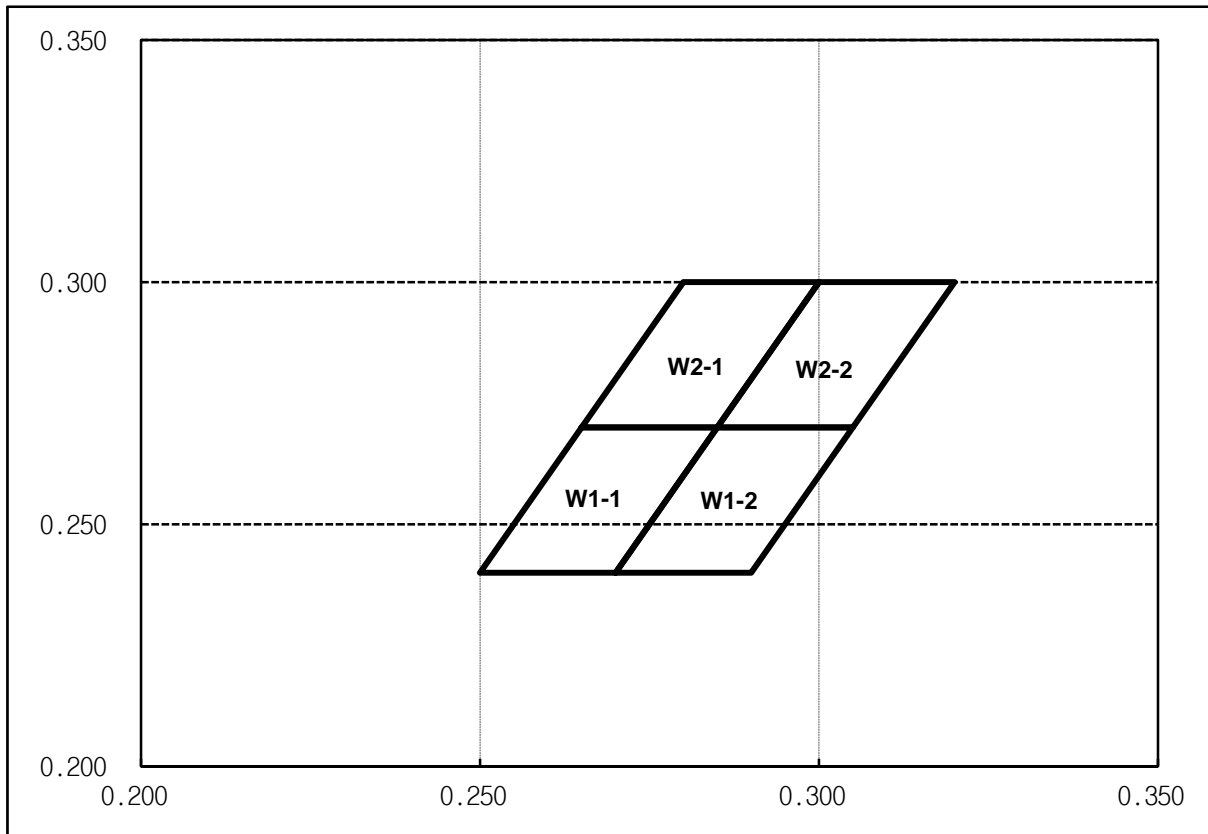

- * The CIE(1931) Standard Colorimetric System
- * Chromaticity Coordinates Measured : 0.01sr(CIE. LED_B)
- * Measurement Uncertainty of the Color Coordinates : ± 0.01

Topview 1608 White LEDs

IWS-164-WXWF-S2



6. Typical Characteristic Curve

Forward Current vs. Forward Voltage

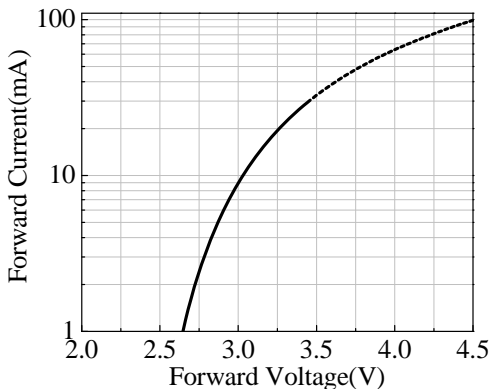

Forward Current vs. Ambient Temperature

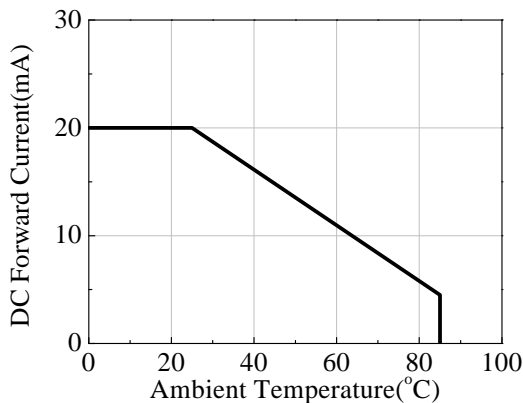

Relative Luminous Intensity vs. Ambient Temperature

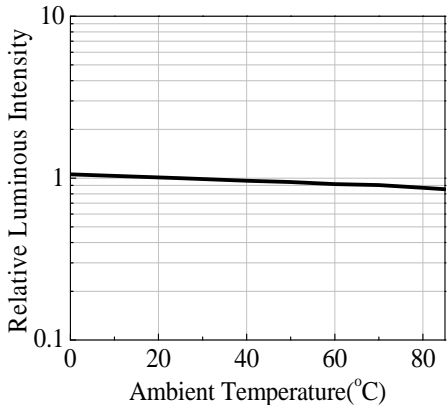

Luminous Intensity vs. Forward Current

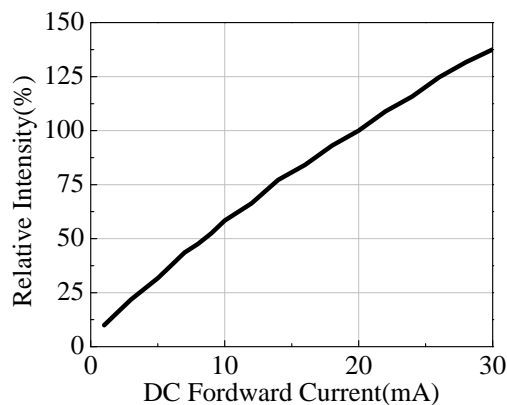

Relative Luminous Intensity vs. Wavelength

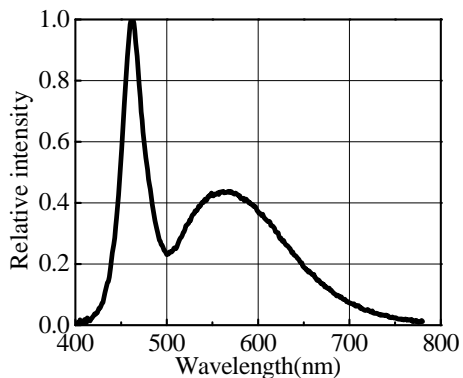

Radiation Diagram

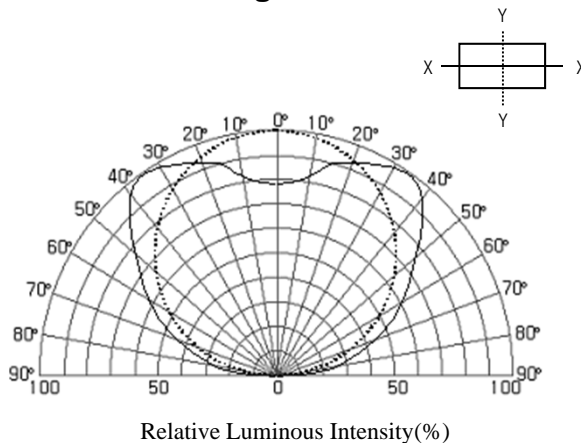

Topview 1608 White LEDs

IWS-164-WXWF-S2



7. Dimension of Tape / Reel

Unit : mm

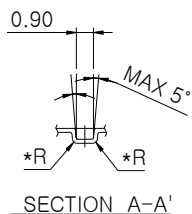
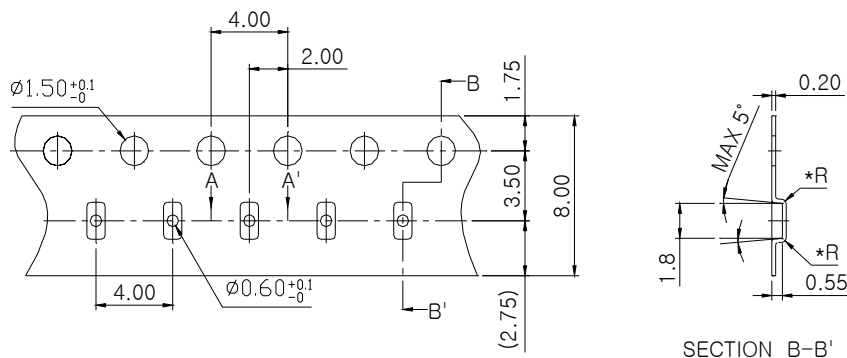

Tolerance ± 0.1 , Unit: mm

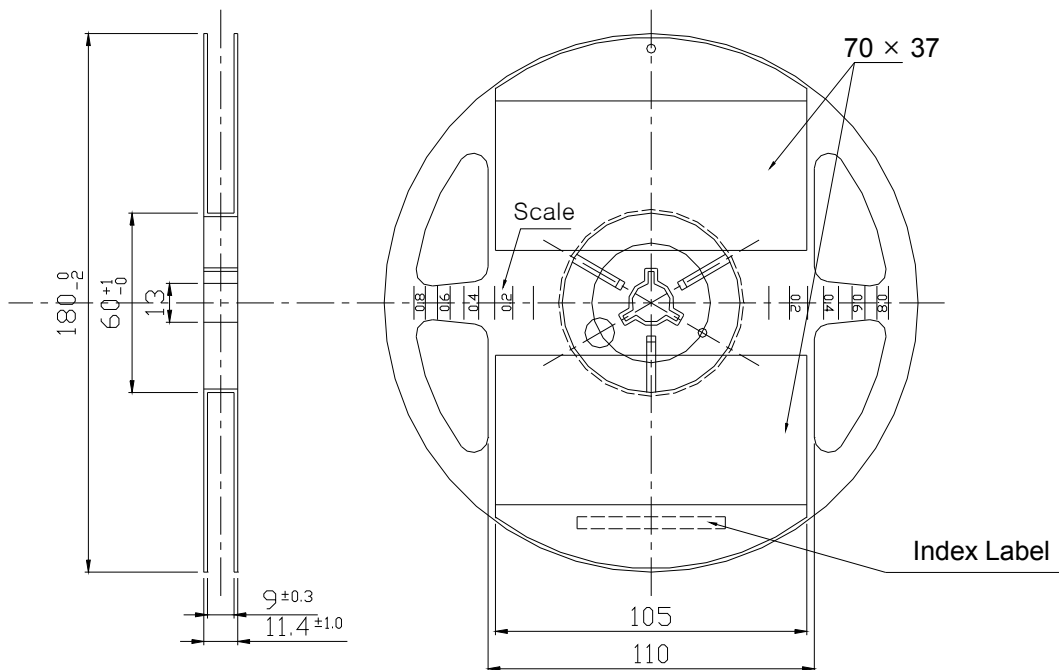

- (1) Quantity : Product are packed in one taping reel of max. 4,000 pcs.
- (2) Cumulative Tolerance : Cumulative Tolerance/10 pitches to be ± 0.2 mm
- (3) Adhesion Strength of Cover Tape : Adhesion strength to be 0.1-0.7N when the cover tape is turned off from the carrier tape at 10°C angle to be the carrier tape.
- (4) Packaging : P/N, Manufacturing data Code No. and quantity to be indicated on a damp proof Package.

Topview 1608 White LEDs

IWS-164-WXWF-S2



8. Packing Dimension

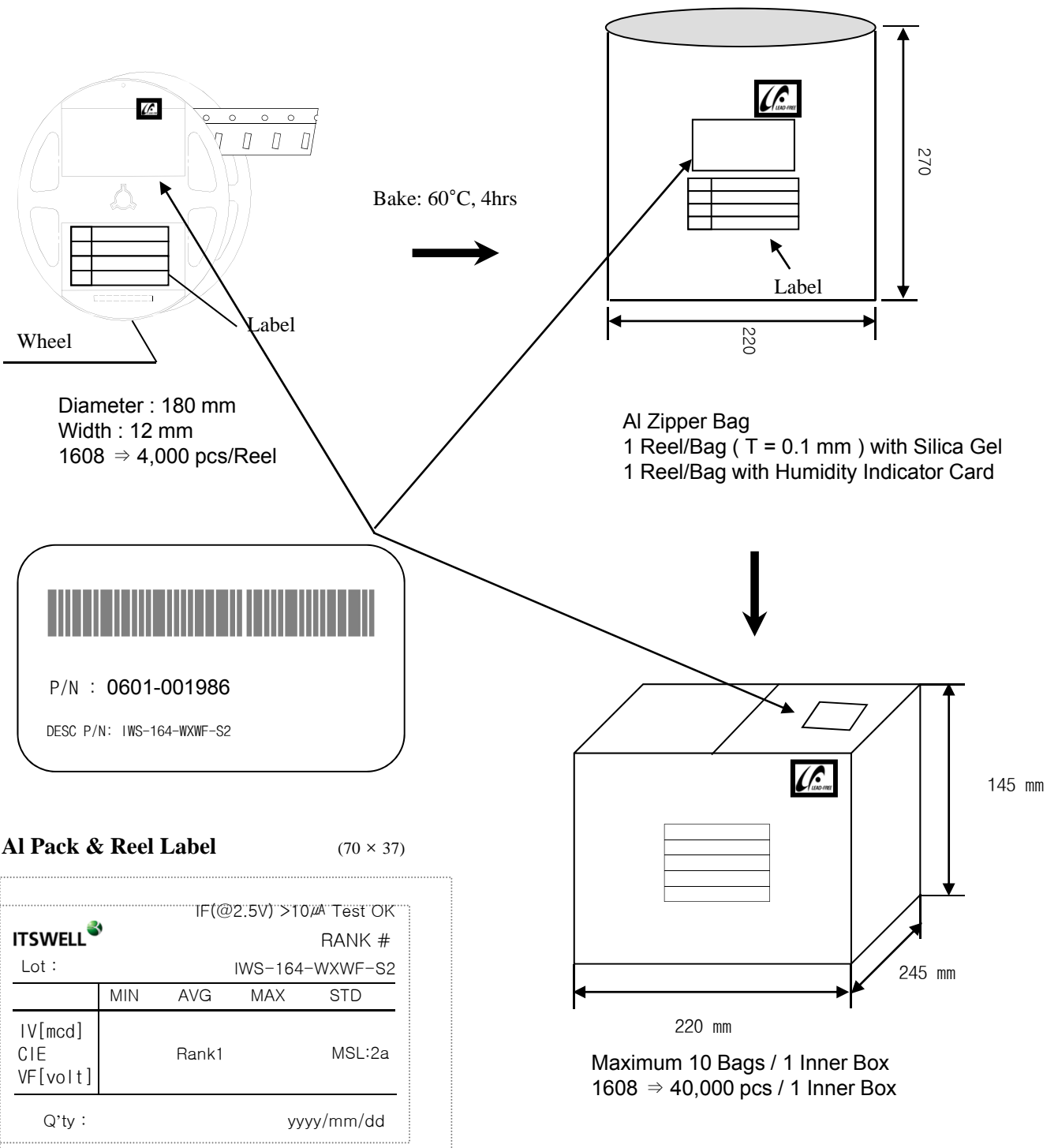

9. Precaution in use

9.1 Soldering Conditions

- When soldering SMD LED , Heat may affect the electrical and optical characteristics of the LEDs.
- In soldering, do not stress the lead frame and the resin part under the high temperature.
- The epoxy part should be protected from mechanical stress or vibration until the SMD LEDs return to room temperature after soldering.
- Preliminary heating to be at 150°C max. for 180 Seconds max.
- Soldering heat to be at 260°C max. for 5 sec. Max.
- For manual Soldering is not more than 3 sec @MAX 350 °C , under soldering iron

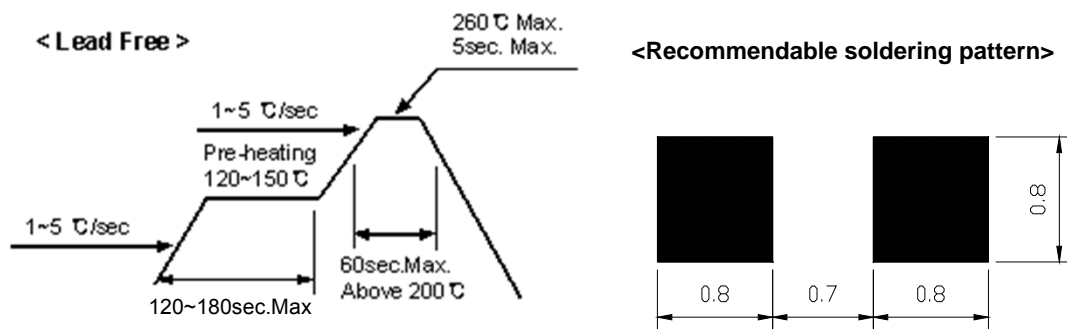

9.2 Storage

- Use within 7 days after opening packing. Store in 10 to 30 °C. SMD LED lead frames are plated silver. The silver surface may be affected by environment which contains corrosive gases and so on. Please avoid conditions which may cause the SMD LED to corrode, tarnish or discolor.

9.3 Static Electricity

- Static electricity or surge voltage damages the SMD LEDs. It is recommended that a wrist band or an anti-electrostatic glove be used when handling the LEDs.
- A tip soldering iron is requested to be grounded. An ionizer should also be installed where there is a risk of static.
- All devices, equipment and machinery must be properly grounded (via 1MΩ). It is recommended that measures be taken against surge voltage to the equipment that mounts the SMD LEDs.

9.4 Cleaning

- Isopropyl Alcohol or Ethylene Alcohol is recommended for 5 minutes at room temperature. Don't use unspecified chemicals as they may cause cracks or haze on the surface of the epoxy resin.
- Before cleaning, a pre-test should be done to confirm whether any damage to the SMD LED will occur.
- Freon solvents should not be used to clean the LEDs because of worldwide regulations.

Topview 1608 White LEDs

IWS-164-WXWF-S2



10. Reliability

10.1 Reliability Test Item

Test Items	Test Conditions	Notes
High Temperature Storage	85 °C, 500 hr.	0/50
Low Temperature Storage	-30 °C, 500 hr.	0/50
Temp. Humidity Storage	50 °C, 95 % RH, 500 hr.	0/50
Steady State Operating life	25 °C, 5 mA, 500 hr.	0/50
High Temperature Operating Life	80 °C, 5 mA, 500 hr.	0/50
Low Temperature Operating Life	-30 °C, 5 mA, 500 hr.	0/50
Steady State Operating life Of High Humidity Heat	85 °C, 85 % RH, 20mA 120 hr.	0/50
Thermal shock	85 °C (60 min.) / -40 °C (60 min.) 30 Cycle (after 2hr and Measurement)	0/50
ESD	HBM, 100 pF, 1.5 kohm, 3 times (Contact Mode : Forward Min 2 kV, Reverse Min 200 V)	0/50
Pressure Cooker Test	121 °C, 2 atm., 99.6 % RH, 48 hr.	0/50
Reflow Test	85 °C/85% 24hr → Reflow 3times (Peak 260 °C 10sec) after 2hr and Measurement	0/50
Temp. Cycle (T/C)	-30 °C → 25 °C → 85 °C → 25 °C 100 cycle (30min → 5min → 30min → 5min)	0/50
내구수명	65 °C/93% ~ -10 °C 5cycle	0/50

10.2 Criteria for Judging the Damage

Items	Test Conditions	Criteria for judgment
Luminous Intensity (IV)	$I_F = 5 \text{ mA}$	More than > 50% of S
Forward Voltage (VF)	$I_F = 5 \text{ mA}$	Less than 120% of U
Reverse Current (IR)	$V_R = 5 \text{ V}$	Less than $10 \mu\text{A}$

* U means the upper limit of specified characteristics, S means initial value.

Topview 1608 White LEDs

IWS-164-WXWF-S2



11. Part Name Description

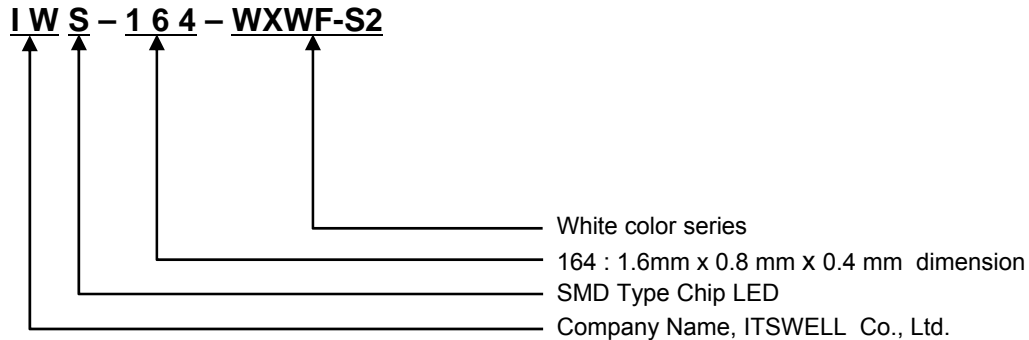

12. Rank Description

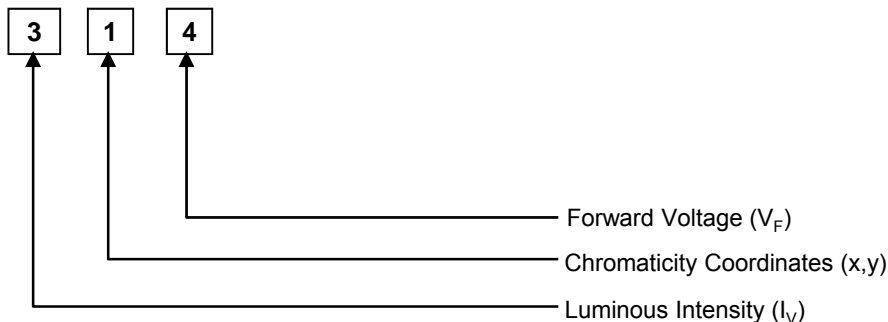

13. ATTENTION : Electric Static Discharge (ESD) Protection



The symbol shown on the page herein to introduce 'Electro-Optical Characteristics'. ESD protection for GaP and AlGaAs based chips is still Necessary even though they are safe in low static-electric discharge. Material in AlInGaP, GaP, or/and InGaN based chips are STATIC SENSITIVE devices. ESD protection has to be considered and taken in the initial design stage. If manual work/process is needed, please ensure the device is well protected from ESD during all the process. LED's ESD Level is 'Class 1' and The range of Forward Voltage is 1V ~ 1999V.

After opening the package, the LED's should be kept at 30°C, 70%RH or less. The LEDs must be dip soldered within seven days(168 hours) after opening the moisture-proof packing. It is better not to use different rank LEDs. If use mixed rank, could not attain your object for highest quality of products.

