

LCD MODULE SPECIFICATION

Customer: _____

Module No.: DNT070WVH82-T1720A

Date: 2023-03-21

Version: 2.0

- Pre-Specification for parameter checking
- Final-Specification for sample approval

For Customer's Acceptance:

Approved by	Comment

Approved by	Checked by	Prepared by
Kanglin.Zhong	Xianren.Zhou	Zaiping.Yang

Table of Contents

Record of Revision.....	3
1 General Specifications.....	4
2 Pin Assignment.....	5
3 Absolute Maximum Ratings	7
4. Electrical Characteristics	7
5 Timing Chart.....	8
6 Optical Characteristics	11
7 Environmental / Reliability Test	14
8 Mechanical Drawing.....	15
9 Precautions for Use of LCD Modules	16

Record of Revision

Rev.	Date	Description	Editor
1.0	2023-03-15	First release	Zaiping.Yang
2.0	2023-03-21	Update the color coordinate parameter	Zaiping.Yang

1 General Specifications

No.	Item	Specification	Remark
1	LCD Size	7.0 inch (Diagonal)	
2	Driver Element	a-Si TFT active matrix	
3	Resolution	800 (RGB) ×480	
4	Display Mode	SFT, Normally Black	
5	Pixel Pitch(mm)	0.0635 (H) × 0.1905 (V)	
6	Display Colors	16.7M	
7	Surface Treatment	Anti-Glare	
8	Color Arrangement	RGB-Stripe	
9	Interface	RGB 24Bit,Digital (TTL)	
10	Viewing Direction	All	
11	Gray Scale Inversion Direction	/	Note 1
12	Outline Dimension (mm)	165.00(W) × 104.0 (H) × 3.50(T)	
13	Active Area (mm)	152.4 (W) × 91.44 (H)	
14	Touch Screen	Without LENS	
15	Display Driver IC		
16	Touch Driver IC	/	

Note 1: Viewing direction for best image quality is different from TFT definition. There is a 180°shift.

Note 2: RoHS compliant.

2 Pin Assignment

2.1 LCD Pin assignment

Match connector: XF2M-4015-1A (OMRON) or equivalent.

PIN	Symbol	I/O	Description	Remark
1	VLED+	P	Power voltage for LED backlight Anode	
2	VLED+	P	Power voltage for LED backlight Anode	
3	VLED-	P	Power voltage for LED backlight Cathode	
4	VLED-	P	Power voltage for LED backlight Cathode	
5	GND	P	Power ground	
6	VCOM (NC)	-	VCOM voltage, No connection	
7	VCC	P	Power for Digital Circuit	
8	MODE (NC)	-	DE or HV mode control.H:DE mode.L:HSD/VSD mode, No connection	
9	DE	I	Data enable	
10	VS (NC)	-	Vsync signal input, No connection	
11	HS (NC)	-	Hsync signal input, No connection	
12	B7	I	BLUE Data Signal(MSB)	
13	B6	I	BLUE Data Signal	
14	B5	I	BLUE Data Signal	
15	B4	I	BLUE Data Signal	
16	B3	I	BLUE Data Signal	
17	B2	I	BLUE Data Signal	
18	B1	I	BLUE Data Signal	
19	B0	I	BLUE Data Signal(LSB)	
20	G7	I	GREEN Data Signal(MSB)	
21	G6	I	GREEN Data Signal	
22	G5	I	GREEN Data Signal	
23	G4	I	GREEN Data Signal	
24	G3	I	GREEN Data Signal	
25	G2	I	GREEN Data Signal	
26	G1	I	GREEN Data Signal	
27	G0	I	GREEN Data Signal(LSB)	
28	R7	I	RED Data Signal(MSB)	
29	R6	I	RED Data Signal	
30	R5	I	RED Data Signal	
31	R4	I	RED Data Signal	
32	R3	I	RED Data Signal	
33	R2	I	RED Data Signal	
34	R1	I	RED Data Signal	
35	R0	I	RED Data Signal(LSB)	
36	GND	P	Power ground	

37	DCLK	I	DOT CLOCK	
38	GND	P	Power ground	
39	L/R	I	Select left or right scanning direction.	
40	U/D	I	Select up or down scanning direction.	
41	VGH (NC)	-	Gate ON Voltage, No connection	
42	VGL (NC)	-	Gate OFF Voltage, No connection	
43	AVDD (NC)	-	Power voltage for Analog circuit. No connection	
44	RESET	I	Global reset pin	
45	VPP (NC)	--	Power supply for OTP, Tianma internal used, must be float on customer side, No connection	
46	VCOM (NC)	-	VCOM voltage, No connection	
47	DITHB (NC)	-	Dithering function.H:6bit resolution(last 2bit of input data Truncated) L:8bit resolution (default setting) No connection	
48	SDA (NC)	-	Serial address / data input/output, must be float on customer side,No connection	
49	SCL (NC)	-	Serial communication clock input, must be float on customer side,No connection	
50	CSB (NC)	-	Serial communication chip select, must be float on customer side ,No connection	

I---Input, O---Output, P--- Power/Ground

Note 1: This LCD module supports DE mode, the pin setting is different from each other. Please refer to the descriptions.

Note 2: Selection of scanning mode.

U/D R/L Function Description

Scan control input		Scanning direction
U/D	L/R	
GND	VCC	Up to down, left to right
VCC	GND	Down to up, right to left
GND	GND	Up to down, right to left
VCC	VCC	Down to up, left to right

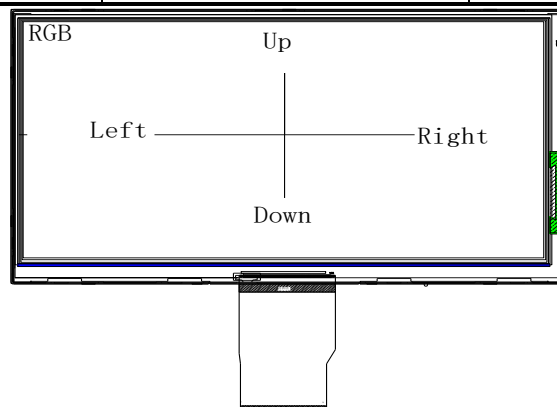

3 Absolute Maximum Ratings

Ta = 25°C

Item	Symbol	Min.	Max.	Unit	Remark
Power Voltage	VCC	-0.50	4.0	V	
Operating Temperature	Top	-20.0	70.0	°C	
Storage Temperature	T _{st}	-30.0	80.0	°C	
Operating and Storage Humidity	H _{stg}	10%	90%	%(RH)	

4. Electrical Characteristics

4.1 Recommended Operating Condition

VCC=3.3V, GND=0V, Ta = 25°C

Item	Symbol	Min.	Typ.	Max.	Unit	Remark
Power supply Voltage	VCC	3.20	3.30	3.40	V	
Input logic high voltage	VIH	0.7VCC	-	VCC	V	R0~R7, G0~G7,0~B7, DE, DCLK, RESET, LR, UD
Input logic low voltage	VIL	0		0.3VCC	V	
Power supply current	I _{VCC}	-	180		mA	VCC=3.3V, color bar pattern

4.2 Backlight Unit Driving Condition

Item	Symbol	Min.	Typ.	Max.	Unit	Remark
Forward Current	I _F	-	180	225	mA	27 LEDs (3 LED Serial, 9LED Parallel)
Forward Current Voltage	V _F	-	9.6	10.5	V	
Backlight Power Consumption	W _{BL}	-	1728	2362.5	mW	
Operating Life Time	--	50000	--	--	hrs	Note 2, Note 3

Note1: The LED driving condition is defined for each module (3 LED Serial, 9 LED Parallel).

Note2: When LCM is operated, the stable forward current should be inputted. And forward voltage is for reference only.

Note3: Optical performance should be evaluated at Ta=25°C When LED is driven at high current, high ambient temperature & humidity condition. The life time of LED will be reduced. Operating life means brightness goes down to 50% initial brightness. Typical operating life time is estimated data.

Note4: The LED driving condition is defined for each LED module.

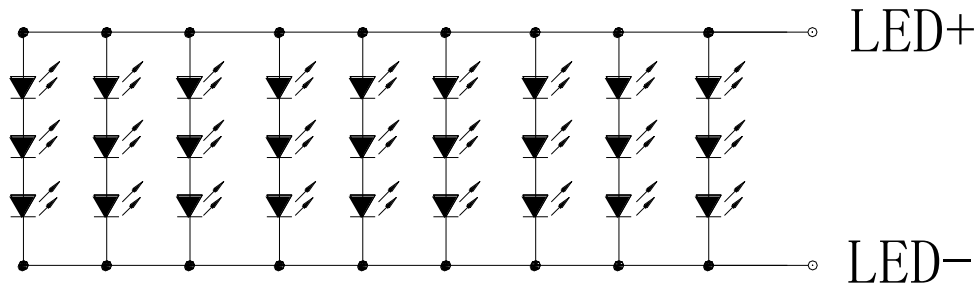

5 Timing Chart

5.1 TFT-LCD Input Timing:DE mode Input Clock and Data timing Diagram:

Parameter	Symbol	Value			Unit	Note
		Min.	Typ.	Max.		
DCLK frequency	fclk	20	33.3	42.8	MHz	
Horizontal display area	thd	800			DCLK	
1 Horizontal Line	th	908	928	1178	DCLK	

Parameter	Symbol	Value			Unit	Note
		Min.	Typ.	Max.		
Vertical display area	tvd	480			H	
Vertical period time	tv	501	525	606	H	

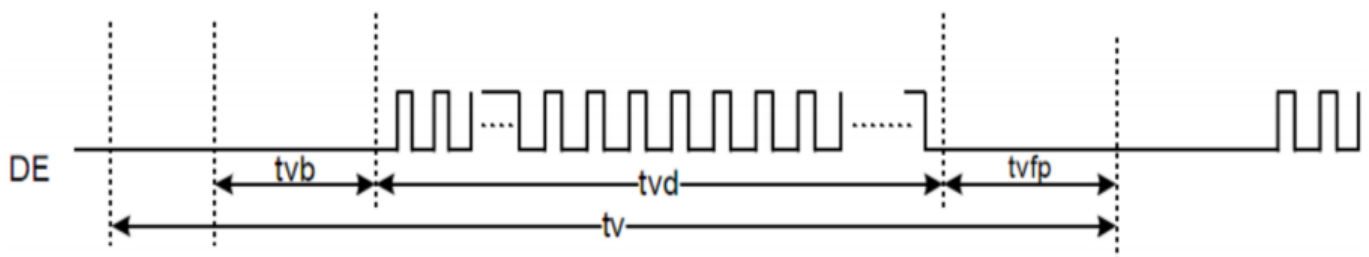

5.2 AC characteristics

VDD=3.3V, GND=0V, Ta=25°C

Parameter	Symbol	Min	Typ	Max	Unit	Remark
DCLK Frequency	Fclk	-	50	55	MHz	
DCLK Pulse Width	T_{cw}	40	-	60	%	
Data Set-up Time	T_{su}	8	-	-	ns	
Data Hold Time	T_{hd}	8	-	-	ns	
Output Stable Time	T_{st}	-	-	9	ns	
DE Set-up Time	T_{dsu}	8	-	-	ns	

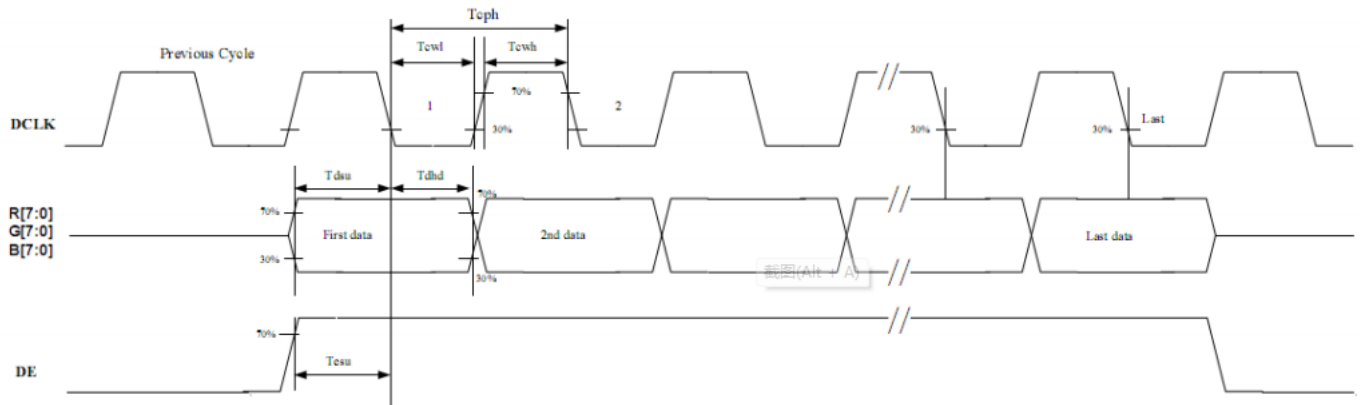

5.3 RESET Timing

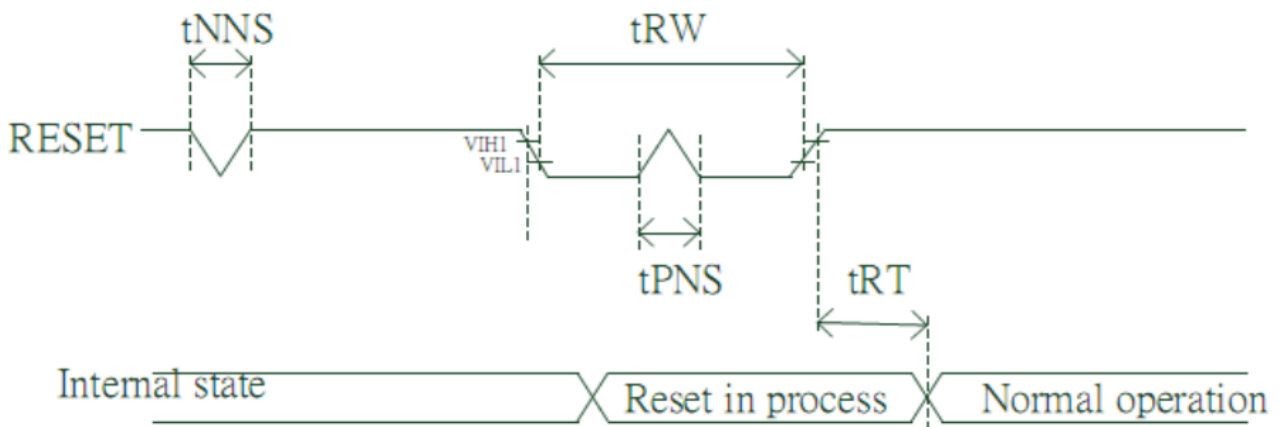

Signal	Parameter	Symbol	Spec.			unit
			min	typ	max	
RESET	RESET pulse width	tRW	40	-	-	us
	RESET complete time	tRT	-	-	40	us
	Positive spike noise width	tPNS	-	-	2	us
	Negative spike noise width	tNNS	-	-	2	us

5.4 POWER ON/OFF SEQUENCE : VCC=VDD

Item	Symbol	1	Typ	Max	Unit	Remark
VDD 3.3V rising time	T1	>90	-	-	us	
VDD to RESET on time	T2	>50		-	us	
RESETB to STBYB on time	T3	>1	-	-	ms	
STBYB to DCLK time	T4	>50			ms	
DCLK to DATA on time	T5	>251	-	-	ms	

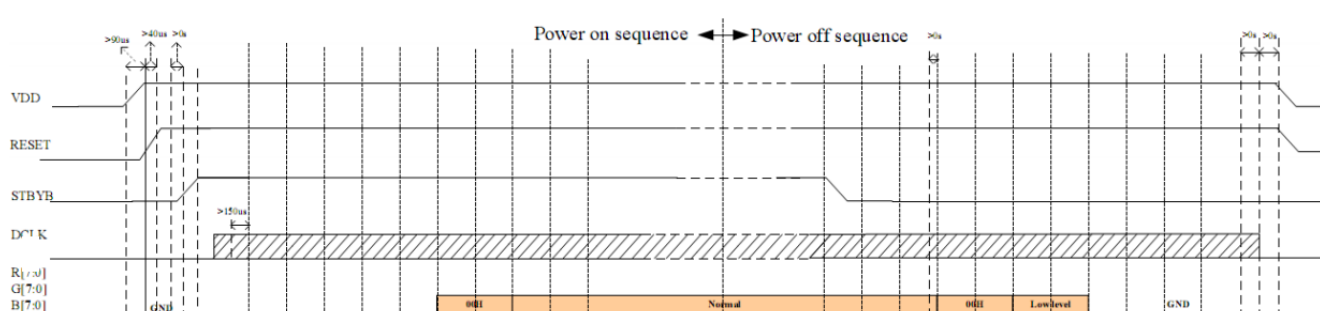

Note1: Power on sequence: VCC\RESET\STBYB\DCLK\DATA ON

Note2: Power off sequence: STBYB\ DATA OFF\DCLK\RESET\VCC

Note3: All of the power and signals should be kept at GND level before power on. If there are residual voltages on them, the LCD might not work properly.

Note4: The power on/off sequence is the first version. It will be updated when the design is fixed.

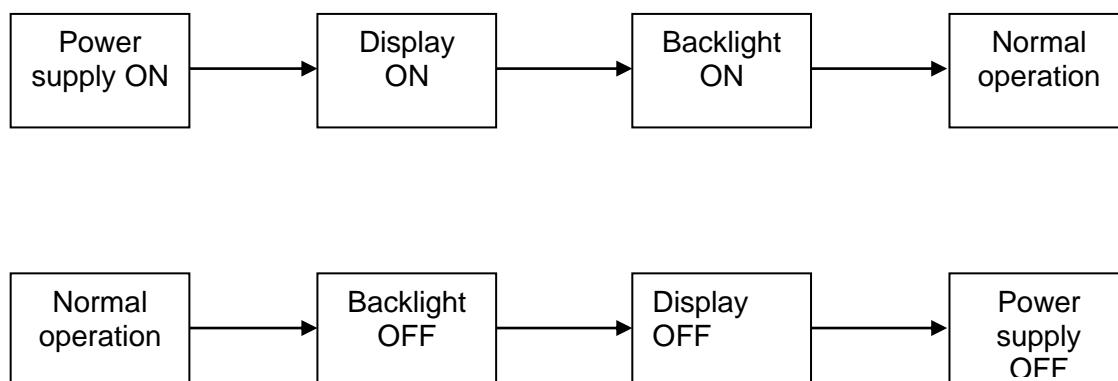

6 Optical Characteristics

Ta=25°C

Item	Symbol	Condition	Min.	Typ.	Max.	Unit	Remark
View Angles	θT	CR ≥ 10	80	85	-	Degree	Note 2
	θB		80	85	-		
	θL		80	85	-		
	θR		80	85	-		
Contrast Ratio	CR	θ=0°	800	1000	-		Note1 Note3
Response Time	T _{ON}	25°C	--	20	30	ms	Note1 Note4
	T _{OFF}						
Chromaticity	White	x	Backlight is on	0.285	0.315	0.345	Note1 Note5
		y		0.283	0.313	0.343	
	Red	x		0.585	0.615	0.645	
		y		0.311	0.341	0.372	
	Green	x		0.317	0.347	0.377	
		y		0.577	0.607	0.637	
	Blue	x		0.122	0.152	0.182	
		y		0.022	0.052	0.082	
Uniformity	U		70	80	-	%	Note1 Note6
NTSC			65	70	-	%	Note 5
Luminance	L		-	500	-	cd/m ²	Note1 Note7

Test Conditions:

1. I_F= 180 mA, V_F=9.6V and the ambient temperature is 25±2°C. humidity is 65±7%
2. The test systems refer to Note 1 and Note 2.

Note 1: Definition of optical measurement system.

Properties are measured at the center point of the LCD screen. All input terminals LCD panel must be ground when measuring the center area of the panel.

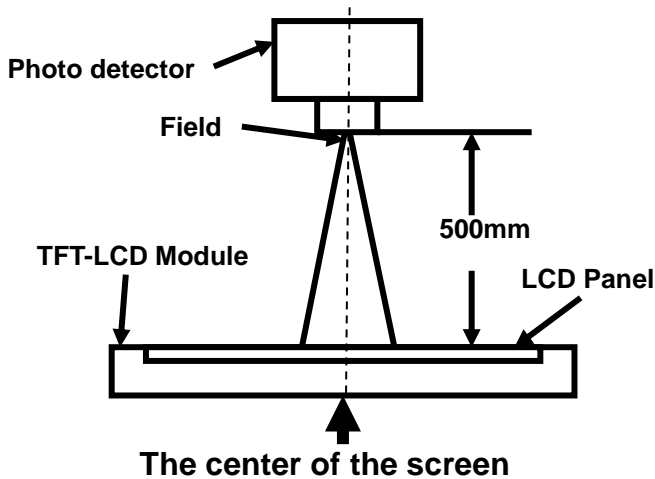

Item	Photo detector	Field
Contrast Ratio	SR-3A	1°
Luminance		
Chromaticity		
Lum Uniformity		
Response Time	BM-7A	2°

Note 2: Definition of viewing angle range and measurement system.

Viewing angle is measured at the center point of the LCD by CONOSCOPE(ergo-80).

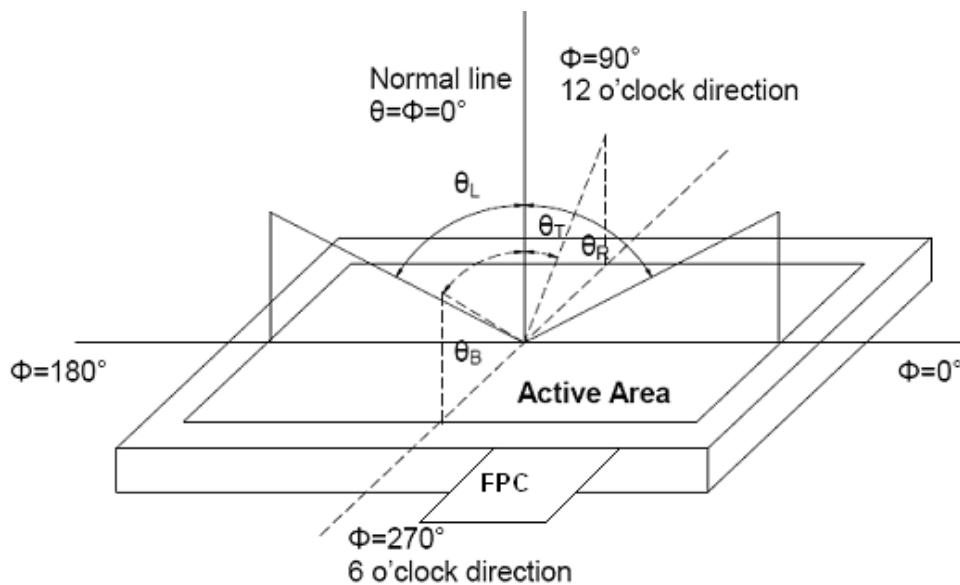

Note 3: Definition of contrast ratio

$$\text{Contrast ratio (CR)} = \frac{\text{Luminance measured when LCD is on the "White" state}}{\text{Luminance measured when LCD is on the "Black" state}}$$

“White state “: The state is that the LCD should drive by V_{white} .

“Black state”: The state is that the LCD should drive by V_{black} .

V_{white} : To be determined V_{black} : To be determined.

Note 4: Definition of response time

The response time is defined as the LCD optical switching time interval between “White” state and “Black” state. Rise time (T_{ON}) is the time between photo detector output intensity changed from 90% to 10%. And fall time (T_{OFF}) is the time between photo detector output intensity changed from 10% to 90%.

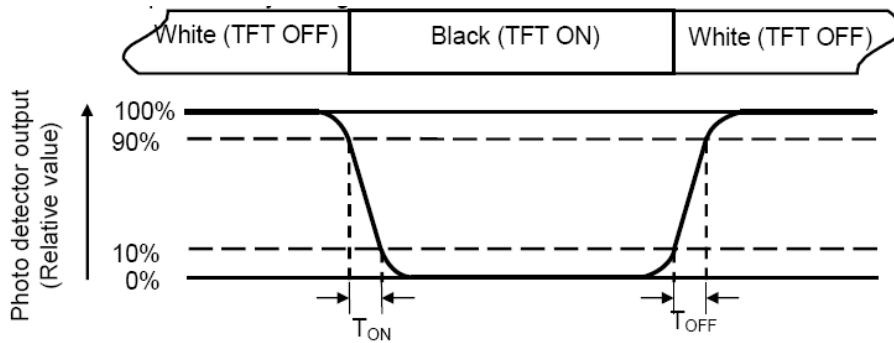

Note 5: Definition of color chromaticity (CIE1931)

Color coordinates measured at center point of LCD.

Note 6: Definition of luminance uniformity

Active area is divided into 9 measuring areas (Refer Fig. 2). Every measuring point is placed at the center of each measuring area.

$$\text{Luminance Uniformity (U)} = L_{\min} / L_{\max}$$

L-----Active area length W----- Active area width

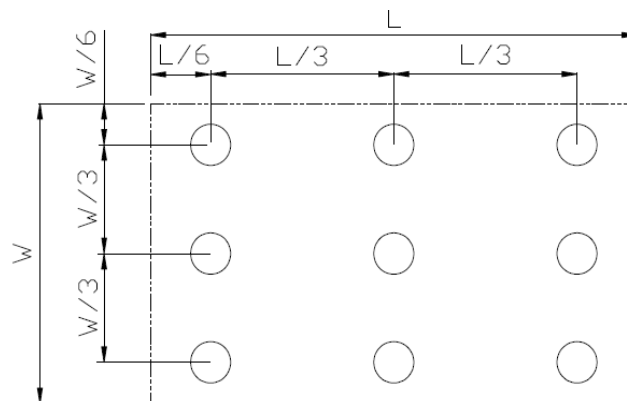

L_{\max} : The measured Maximum luminance of all measurement position.

L_{\min} : The measured Minimum luminance of all measurement position.

Note 7: Definition of luminance:

Measure the luminance of white state at center point.

7 Environmental / Reliability Test

No	Test Item	Condition	Remarks
1	High Temperature Operation	Ts = +70°C, 240 hours	No abnormalities in functions
2	Low Temperature Operation	Ta = -20°C, 240 hours	No abnormalities in functions
3	High Temperature Storage	Ta = +80°C, 240 hours	No abnormalities in functions
4	Low Temperature Storage	Ta = -30°C, 240 hours	No abnormalities in functions
5	Storage at High Temperature and Humidity	Ta = +60°C, 90% RH max, 240 hours	No abnormalities in functions
6	Thermal Shock (non-operating)	-30°C 30 min ~ +70°C 30 min, Change time: 0.5 hour ← 5 min → 0.5 hour. 10 Cycle	Start with cold temperature, End with high temperature,
7	ESD	C=150pF, R=330Ω, 5point/panel Air: ±8Kv, 5times; Contact: ±4Kv, 5times (Environment: 15°C ~ 35°C, 30% ~ 60% RH, 86Kpa ~ 106Kpa)	No abnormalities in functions

Note1: Ts is the temperature of panel's surface.

Note2: Ta is the ambient temperature of samples.

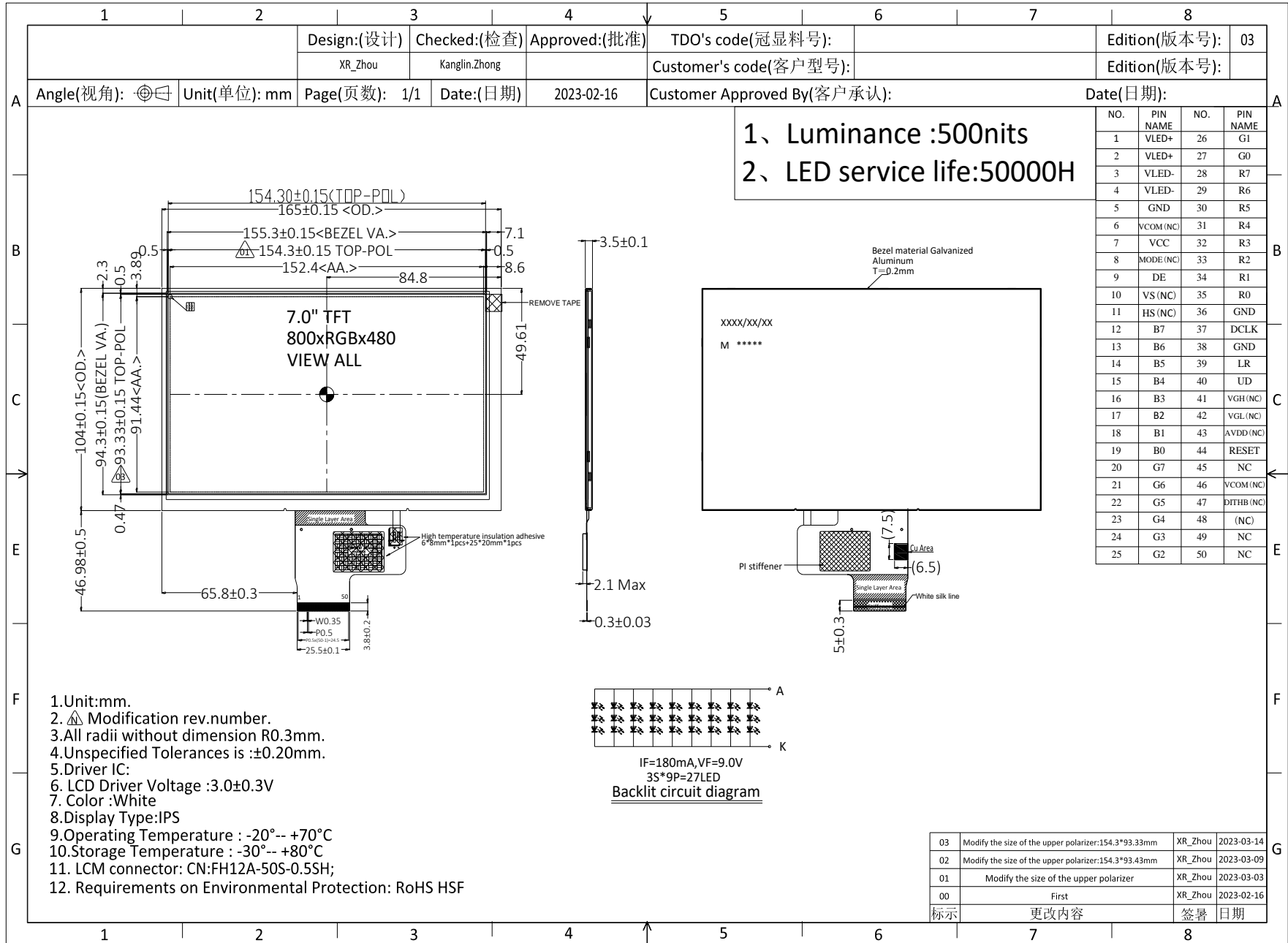

03	Modify the size of the upper polarizer:154.3*93.33mm	XR_Zhou	2023-03-14
02	Modify the size of the upper polarizer:154.3*93.43mm	XR_Zhou	2023-03-09
01	Modify the size of the upper polarizer	XR_Zhou	2023-03-03
00	First	XR_Zhou	2023-02-16
标示	更改内容	签署	日期

9 Precautions for Use of LCD Modules

Handling Precautions

9.1.1 The display panel is made of glass. Do not subject it to a mechanical shock by dropping it from a high place, etc.

9.1.2 If the display panel is damaged and the liquid crystal substance inside it leaks out, be sure not to get any in your mouth, if the substance comes into contact with your skin or clothes, promptly wash it off using soap and water.

9.1.3 Do not apply excessive force to the display surface or the adjoining areas since this may cause the color tone to vary.

9.1.4 The polarizer covering the display surface of the LCD module is soft and easily scratched. Handle this polarizer carefully.

9.1.5 If the display surface is contaminated, breathe on the surface and gently wipe it with a soft dry cloth. If still not completely clear, moisten cloth with one of the following solvents:

- Isopropyl alcohol
- Ethyl alcohol

Solvents other than those mentioned above may damage the polarizer. Especially, do not use the following:

- Water
- Ketone
- Aromatic solvents

9.1.6 Do not attempt to disassemble the LCD Module.

9.1.7 If the logic circuit power is off, do not apply the input signals.

9.1.8 To prevent destruction of the elements by static electricity, be careful to maintain an optimum work environment.

9.1.8.1 Be sure to ground the body when handling the LCD Modules.

9.1.8.2 Tools required for assembly, such as soldering irons, must be properly ground.

9.1.8.3 To reduce the amount of static electricity generated, do not conduct assembly and other work under dry conditions.

9.1.8.4 The LCD Module is coated with a film to protect the display surface. Be care when peeling off this protective film since static electricity may be generated.

Storage Precautions

9.2.1 When storing the LCD modules, avoid exposure to direct sunlight or to the light of fluorescent lamps.

9.2.2 The LCD modules should be stored under the storage temperature range. If the LCD modules will be stored for a long time, the recommend condition is: Temperature : 0°C ~ 40°C Relatively humidity: ≤80%

9.2.3 The LCD modules should be stored in the room without acid, alkali and harmful gas.

Transportation Precautions

9.3.1 The LCD modules should be no falling and violent shocking during transportation, and also should avoid excessive press, water, damp and sunshine.