

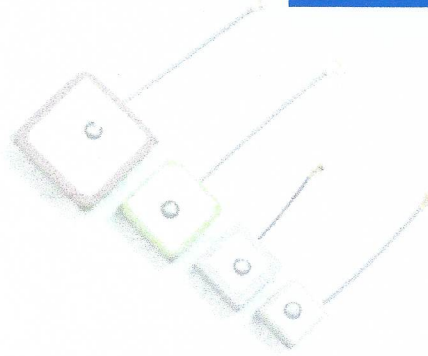

Active Antenna



DATA Sheet

Product Name : GNSS L1&L2 Active Ascenkorea

Antenna Part No. : AKA540

	Designed	Checked		Approved
Date	/	/	/	/

Revision no	Content	Page	Date	Name
-	First Documented	-	2019.04.11	I.J.Jeong

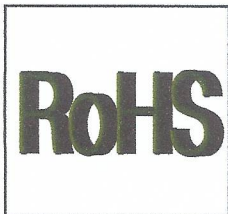

■ HEAD OFFICE Rm 905, 2 Gasandigital 1 RO, Geumcheongu, Seoul, Korea TEL: 02-6267-7810 FAX: +82-2-6499-2940	Designed	Checked		Approved
	2019/04/11			2019/04/11

Notes
 The contents of this data sheet are subject to change without notice.

	SPECIFICATION	Page
	AKA540	2/13

1. Specifications

1.1 Patch Antenna Element Electrical Specifications

No	Item	Spec.		Unit	Remark
		L1 Band	L2 Band		
1	Frequency	1559.0~1606.0	1197.0~1249.0	MHz	Note: 1)
2	Polarization	RHCP	RHCP	-	Note: 1)
3	Gain @ Zenith	Typ. 3.5	Typ. 0~2.0	dBic	Note: 1)
4	Axial Ratio	Typ. 2.0 @Zenith	Typ. 2.0 @Zenith	dB	Note: 1)
5	Bandwidth @ -10dB	200 min.	200 min.	MHz	Note: 1)
6	Impedance	50		ohm	Note: 1)
7	Patch antenna	ASPA - A28A (Ø42 – 14T)			Note: 1)

Note: 1) Measured on the 150Ø mm ground plane

1.2 LNA Electrical Specifications

No	Item	Spec.		Unit	Remark
		L1 Band	L2 Band		
1	Frequency	1559.0~1606.0	1197.0~1249.0	MHz	
2	Gain	28.0 ± 3.0 @5V	28.0 ± 3.0 @5V	dB	
3	Noise Figure	Typ. 2.8 @5V	Typ. 3.2 @5V	dB	
4	Output VSWR	Typ. 2.0 : 1	Typ. 2.0 : 1	-	
5	Voltage Range	DC 3.0~5.0		V	
6	Maximum Voltage Rating	10		V	
6	Current	15.0 Typ. @ 5.0V		mA	
7	Impedance	50		ohm	

	SPECIFICATION	Page
	AKA540	3/13

1.3 Overall Performance

No	Item	Spec.		Unit	Remark
		L1 Band	L2 Band		
1	Frequency	1559.0~1606.0	1197.0~1249.0	MHz	Note:4)
2	Total System Zenith Gain	Typ. 24~27	Typ. 24~27	dBic	
3	Axial Ratio	Typ. 2.0 @Zenith	Typ. 2.0 @Zenith	dB	
4	Output VSWR	Typ. 2.0 : 1	Typ. 2.0 : 1	-	
5	Output Impedance	50		ohm	

Note:4) Measured on the 150Ø mm ground plane, DC 5V, 5m cable.

1.4 Mechanical Specifications

No	Item	Spec.	Unit
1	Size	82.0(L) * 60.0(W) * 22.5(T) ± 0.5	mm
2	Cable / Connector	RG174 Φ2.8 mm L=5000±100 mm /SMA(M)	-
3	Weight	170	g
4	Mounting	Magnetic base & Screw	-
5	Housing Color/Material	Black/PC+ABS	-

1.5 Radiation Inspections

No	Item	Spec.		Unit
		L1 Band	L2 Band	
1	Frequency	1559.0 ~ 1606.0	1197.0 ~ 1249.0	MHz
2	S21	Min. -6.0		dB
3	Current	13.0 ~ 17.0		mA

2. Appearance

2.1 Outer Appearance

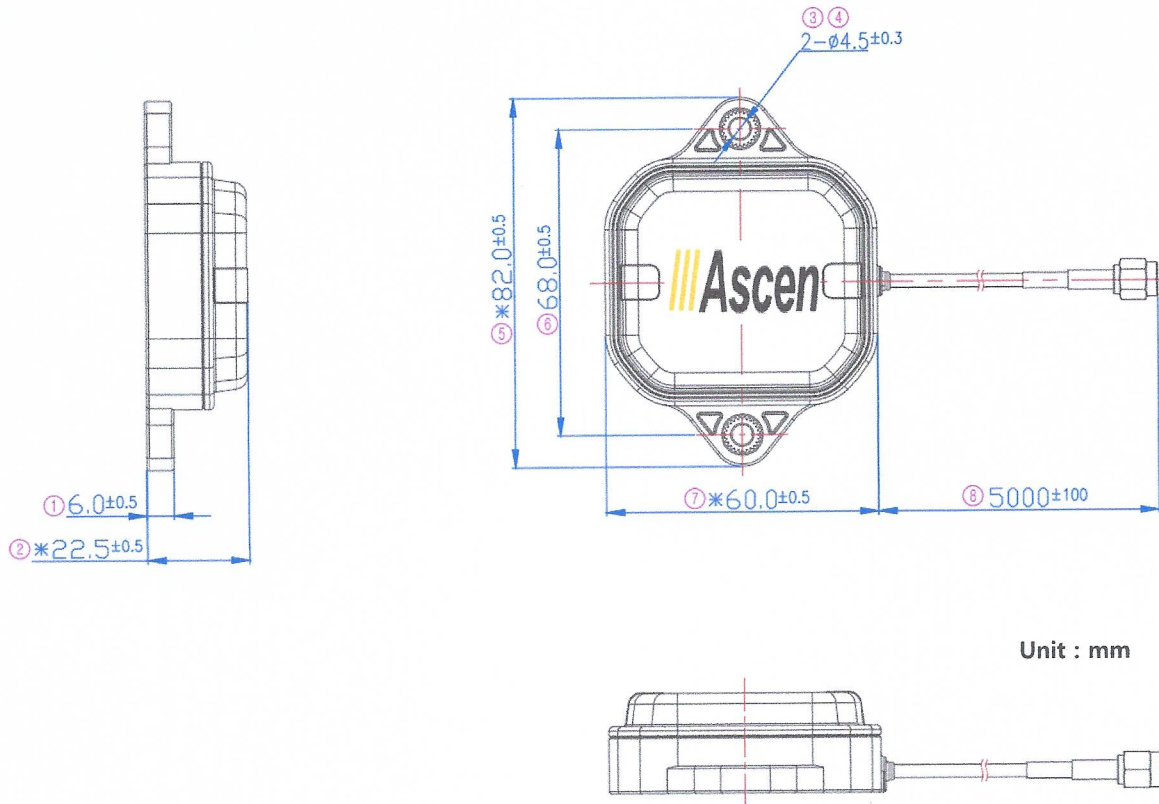

3. Part No.

Part No. : AGA XXXXXX - XX - XX
 (1) (2) (3) (4)

- (1) : ASCEN GNSS Active Antenna
- (2) : Antenna Size
- (3) : Revision No.
- (4) : Model No.

4. Environmental Specifications

No	Item	Spec.	Unit
1	Operating Temp.	-40 ~ +85	°C
2	Storage Temp.	-40 ~ +85	°C
3	Water Proof	IP67	-

5. Typical Characteristics

5.1 Typical S11 of Patch Antenna

(Test condition: with case, Hybrid coupler, on the 150Ø mm Ground plane)

* L1 Band (1559~1606MHz)

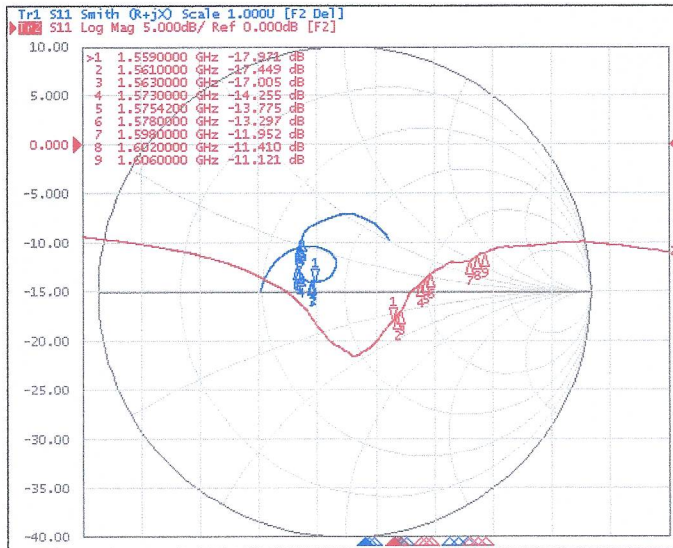

[Log mag & Smith Chart]

* L2 Band (1197~1249MHz)

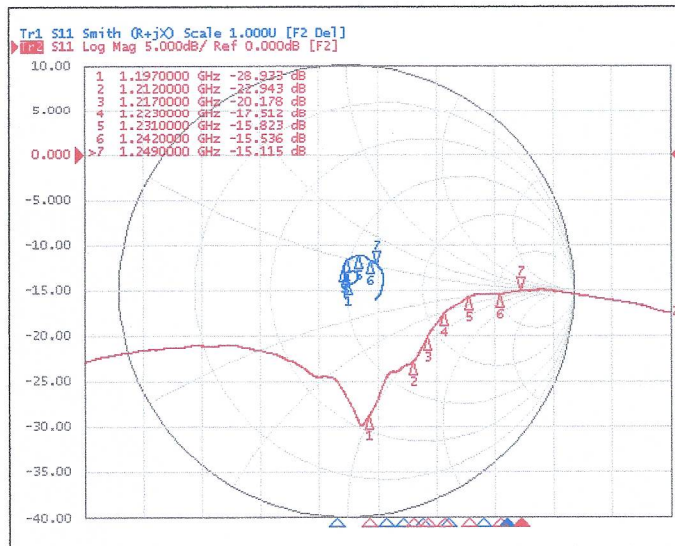

[Log mag & Smith Chart]

5.2 Typical LNA Gain

(Test condition: Only LNA Circuit, Semi-Ridged SMA Cable, 16mA @ 5V Voltage.)

5.2.1 L1 band

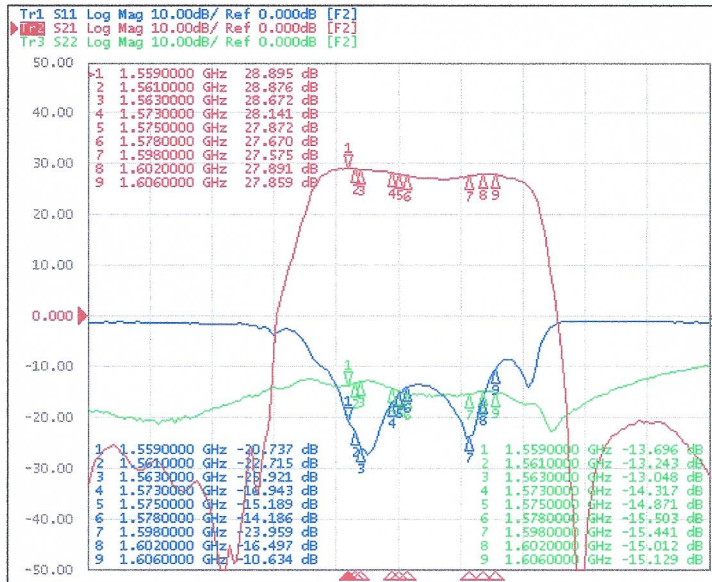

Frequency (MHz)	1559	1561	1563	1573	1575	1578	1598	1602	1606
Gain(dB)	28.89	28.87	28.67	28.14	27.87	27.67	27.57	27.89	27.85
NF(dB)	2.62	2.53	2.51	2.26	2.25	2.26	2.33	2.28	2.35

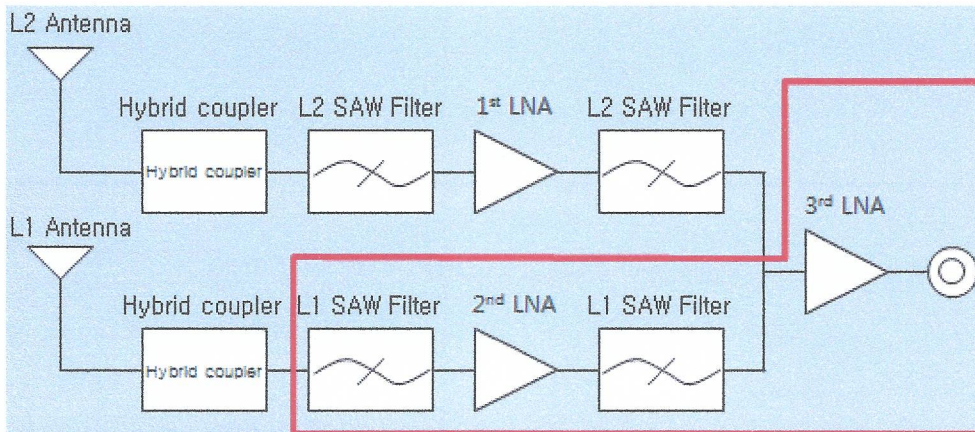

5.2.2 L2 band (In case of applying SAW Filter of supplier 'Sawnics')

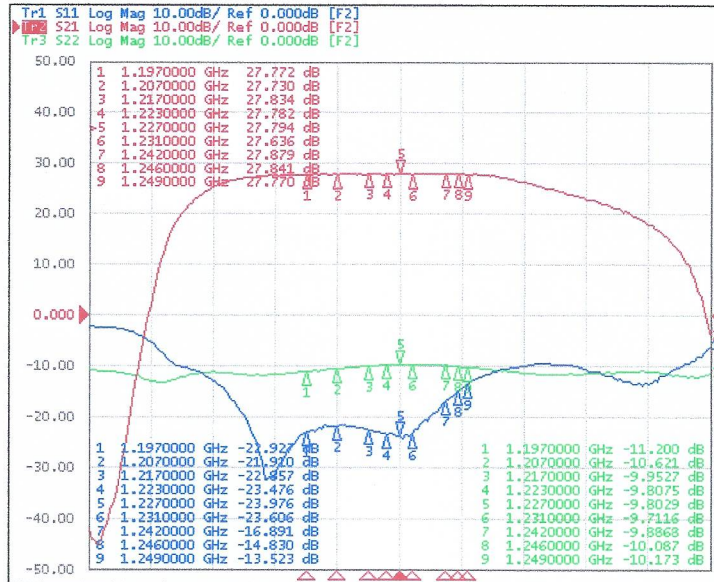

Frequency (MHz)	1197	1207	1217	1223	1227	1231	1242	1246	1249
Gain(dB)	27.77	27.73	27.83	27.78	27.79	27.63	27.87	27.84	27.77
NF(dB)	3.14	2.97	2.85	2.94	2.93	2.93	3.08	3.10	3.17

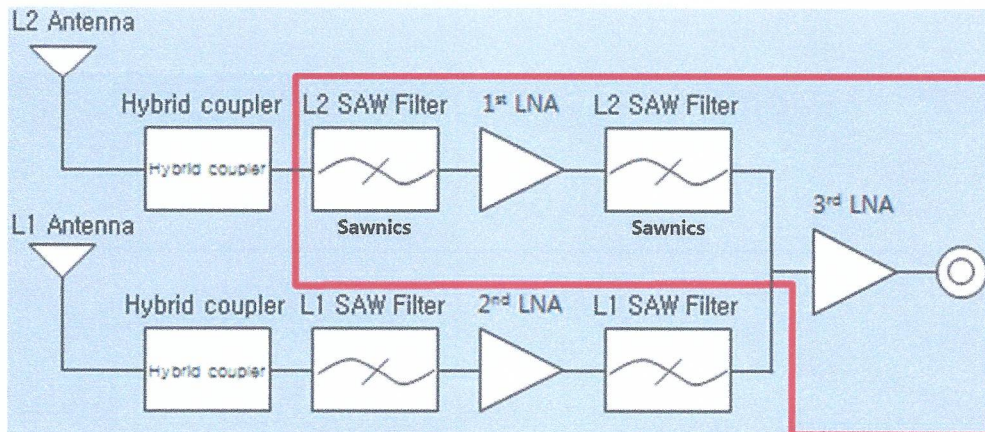

5.2.3 L2 band (In case of applying SAW Filter of supplier 'TDK')

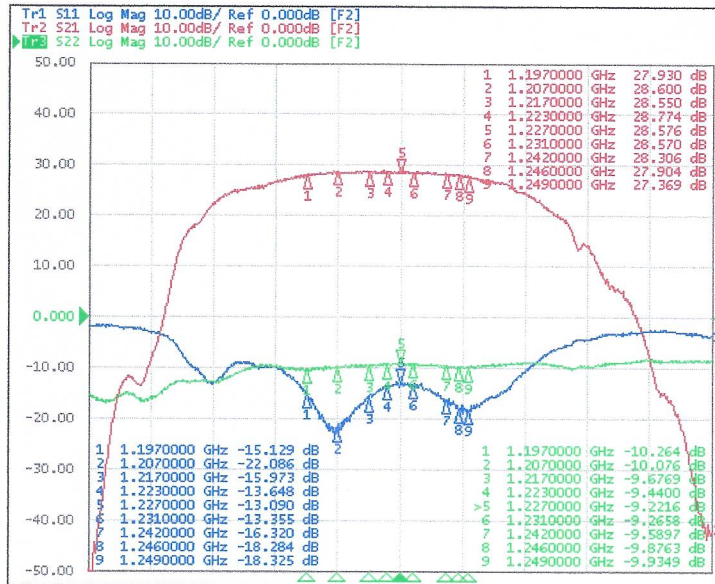

Frequency (MHz)	1197	1207	1217	1223	1227	1231	1242	1246	1249
Gain(dB)	27.93	28.60	28.55	28.77	28.57	28.57	28.30	27.90	27.36
NF(dB)	3.75	3.40	3.03	2.91	2.81	2.84	3.09	3.28	3.49

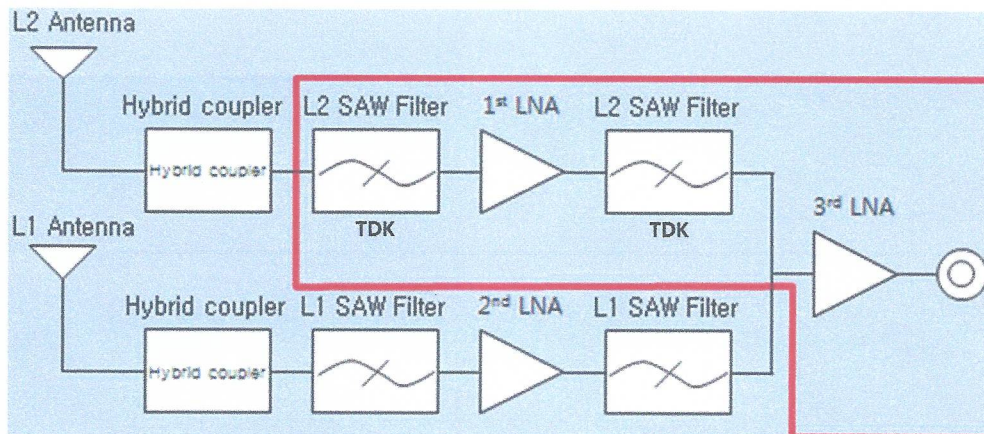

	SPECIFICATION	Page
	AKA540	9/13

5.3 Overall Gain / Axial Ratio of active antenna

(Test condition: 5m RG174 SMA Cable, On 150Ø mm ground plane, Current 16mA @ 5V Voltage)

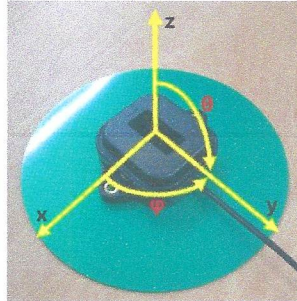

5.3.1 L1 Band Antenna RHCP Gain

Frequency [MHz]	Average Gain [dBic]	Peak Gain [dBic]	Zenith Gain [dBic]	Zenith AR [dB]
1559	18.46	25.26	25.04	1.17
1561	18.79	25.62	25.38	1.13
1563	18.99	25.83	25.59	1.08
1573	18.79	25.67	25.48	0.99
1575	18.67	25.56	25.38	0.96
1578	18.53	25.43	25.25	0.95
1598	19.09	25.91	25.73	0.95
1602	19.07	25.94	25.72	1.02
1606	18.39	25.25	25.06	1.13

5.3.2 L2 Band Antenna RHCP Gain (In case of applying SAW Filter of supplier 'Sawnics')

Frequency [MHz]	Average Gain [dBic]	Peak Gain [dBic]	Zenith Gain [dBic]	Zenith AR [dB]
1197	18.12	25.45	25.24	1.55
1207	19.49	26.81	26.58	1.33
1217	19.91	26.99	26.78	1.08
1223	20.37	27.31	27.09	0.92
1227	20.32	27.22	26.98	0.88
1231	20.16	27.08	26.84	0.87
1242	18.77	25.95	25.79	0.93
1246	18.08	25.31	25.19	0.94
1249	17.49	24.89	24.63	0.95

	SPECIFICATION	Page
	AKA540	10/13

5.3.3 L2 Band Antenna RHCP Gain (In case of applying SAW Filter of supplier 'TDK')

Frequency [MHz]	Average Gain [dBic]	Peak Gain [dBic]	Zenith Gain [dBic]	Zenith AR [dB]
1197	18.50	24.47	24.18	1.55
1207	20.27	26.23	26.05	1.21
1212	20.32	26.29	26.14	1.04
1217	19.65	25.59	25.45	1.09
1223	19.36	25.33	25.19	1.09
1227	19.35	25.43	25.28	1.13
1231	18.74	25.22	25.04	1.26
1242	18.29	24.84	24.71	1.30
1246	17.69	24.31	24.19	1.29

5.4 Radiation patterns of Active antenna

(Test condition: 5m RG174 SMA Cable, on 150Ø mm ground plane, Current 16mA @ 5V Voltage)

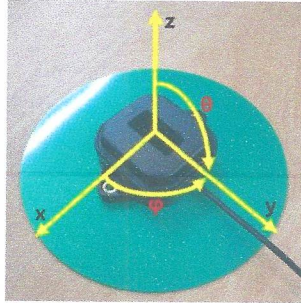

5.4.1 L1 Band

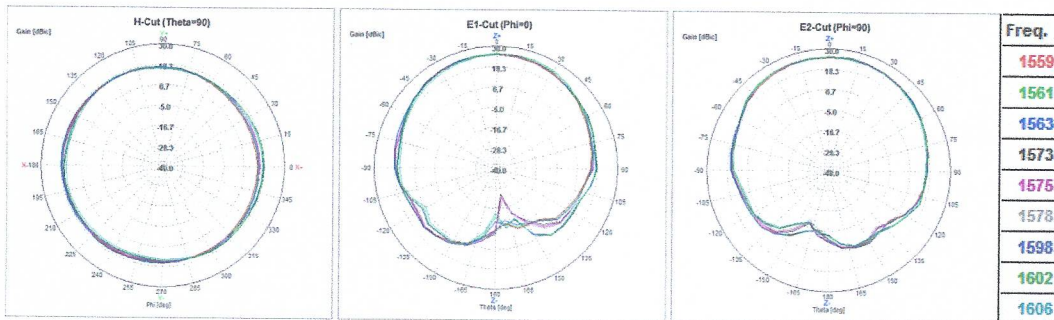

5.4.2 L2 Band (In case of applying SAW Filter of supplier 'Sawnics')

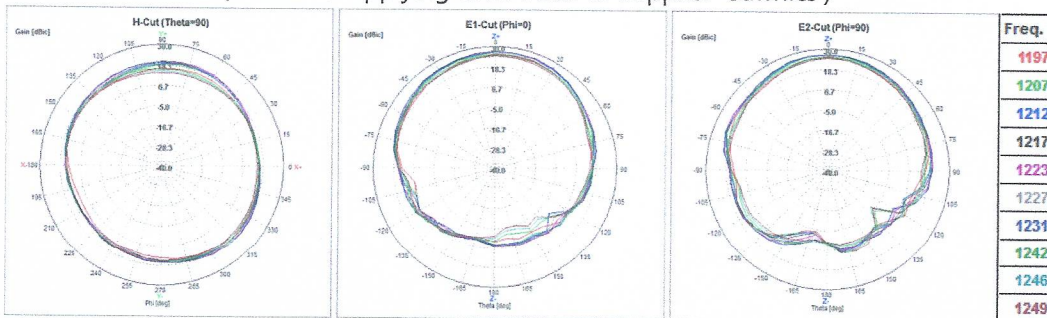

5.4.3 L2 Band (In case of applying SAW Filter of supplier 'TDK')

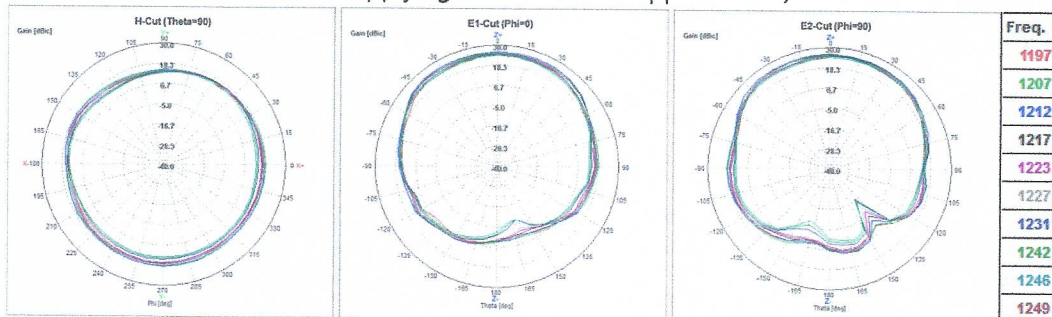

6. Test Method

6.1 LNA Gain and Noise Figure and Current Measurement

6.1.1 Measurement Equipment

- Noise Figure Analyzer, Power Supply, Bias Tee

6.1.2 Measurement Diagram

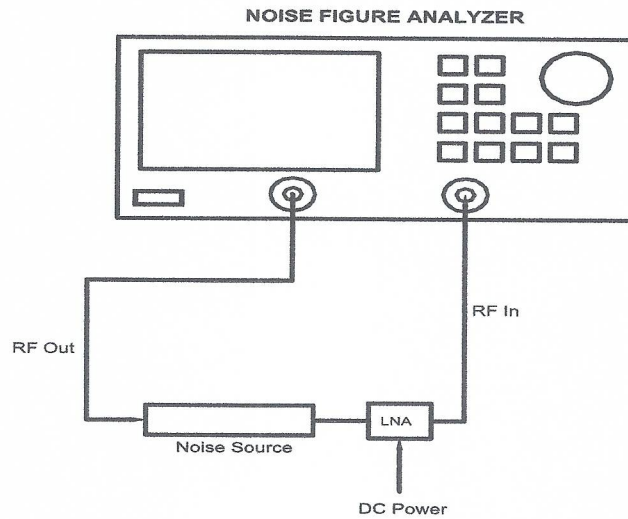

6.2 Overall Performance Measurement

6.2.1 Measurement Equipment

- Network Analyzer, Anechoic chamber System, Power Supply, Bias-Tee

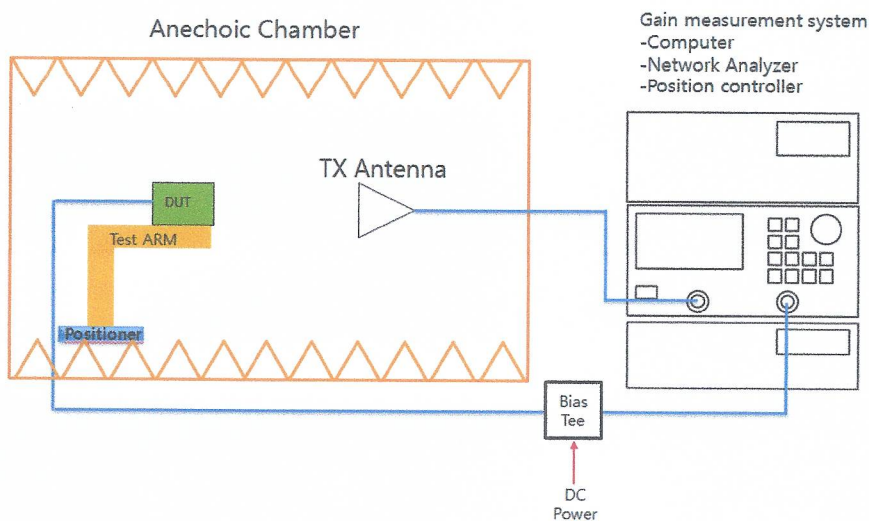

	SPECIFICATION	Page
	AKA540	13/13

6.3 Radiation inspection

6.3.1 Measurement Equipment

- Manual Jig, Network Analyzer, DC power supply, Bias Tee

6.3.2 Measurement Diagram

